

Grant Vortex Eco

External and External System Condensing Oil Boiler Range

Installation and Servicing Instructions

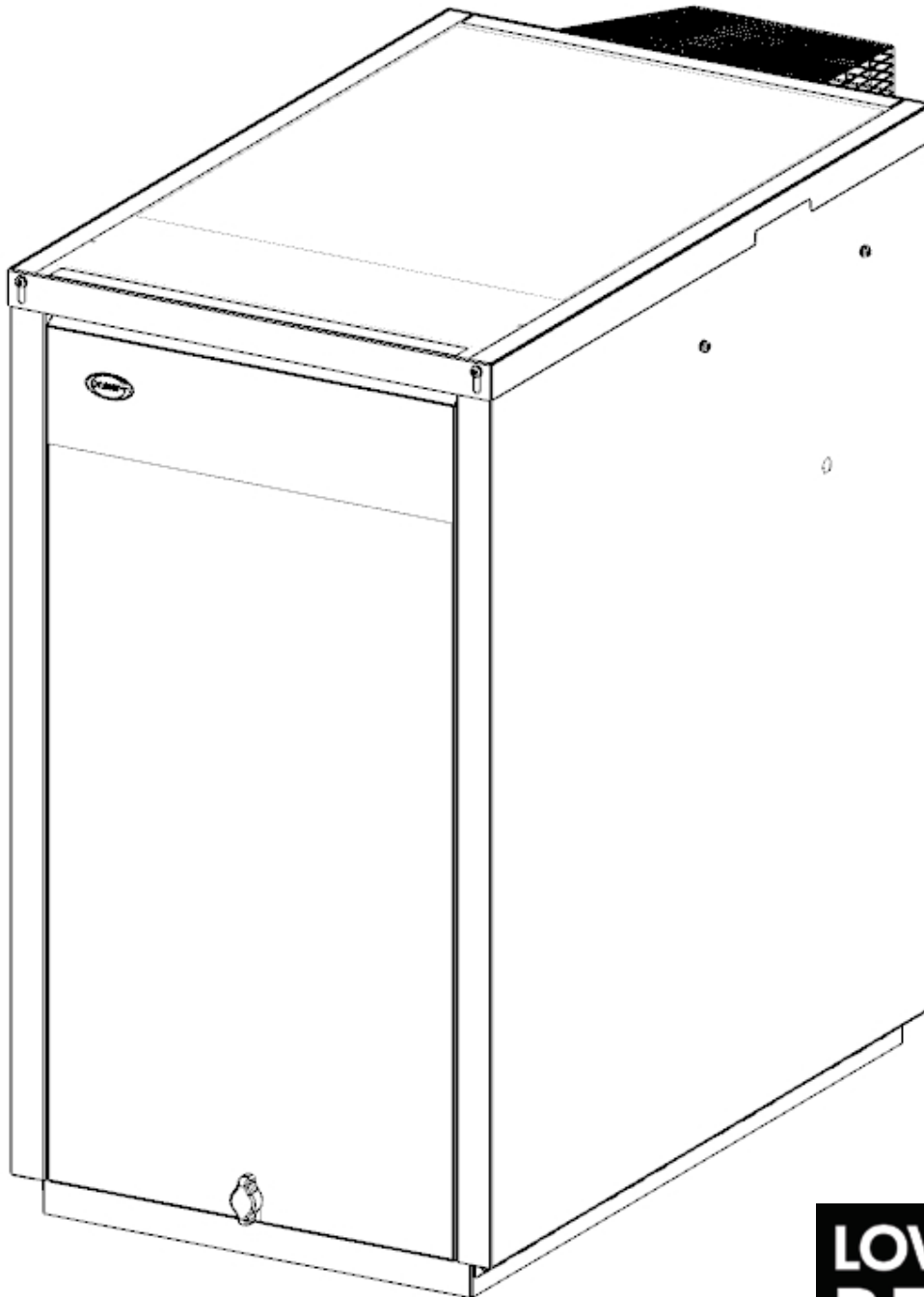

IMPORTANT NOTE FOR INSTALLERS

These instructions are intended to guide installers on the installation, commissioning and servicing of the Grant Vortex oil boiler. After installing the boiler, leave these instructions with the user.

A user handbook is available to guide users in the operation of the oil boiler.

SPECIAL TEXT FORMATS

The following special text formats are used in these instructions for the purposes listed below:

! WARNING !

Warning of possible human injury as a consequence of not following the instructions in the warning.

! CAUTION !

Caution concerning likely damage to equipment or tools as a consequence of not following the instructions in the caution.

! NOTE !

Used for emphasis or information not directly concerned with the surrounding text but of importance to the reader.

PRODUCT CODES AND SERIAL NUMBERS COVERED

The serial numbers used on Grant oil boilers consist of a fifteen digit numerical code with the final three digits being the product identifier.

For example:

100000200218757

These instructions cover the following product codes and serial numbers:

Product code	Serial number identifier
VTXOMECO15/21	757
VTXOMECO21/26	758
VTXOMECO26/35	759
VTXSOMECO15/21	774
VTXSOMECO21/26	775
VTXSOMECO26/35	776



GRANT ENGINEERING (UK) LIMITED

Hopton House, Hopton Industrial Estate, Devizes, Wiltshire, SN10 2EU

Tel: +44 (0)1380 736920 Fax: +44 (0)1380 736991

Email: info@grantuk.com www.grantuk.com

This manual is accurate at the date of printing but will be superseded and should be disregarded if specifications and/or appearances are changed in the interests of continued product improvement. However, no responsibility of any kind for any injury, death, loss, damage or delay however caused resulting from the use of this manual can be accepted by Grant Engineering (UK) Limited, the author or others involved in its publication.

All goods sold are subject to our official Conditions of Sale, a copy of which may be obtained on application.

© Grant Engineering (UK) Limited. No part of this manual may be reproduced by any means without prior written consent.

SERVICING

The boiler should be serviced at least every twelve months and the details entered in the Service Log in the user handbook.

FUEL TYPE

All Grant Vortex boilers are suitable for use with Class C2 Kerosene.

The use of Class D Gas Oil on all Grant Vortex Low NOx and Blue Flame boilers DOES NOT comply with ErP requirements or EU regulations, and as a result Grant UK does not condone its use.

To use Bio-Kerosene (B30K), refer to the information below:

OPERATION ON BIO-FUEL

All Grant Vortex condensing boilers manufactured since May 2011 are suitable for operation on both standard Kerosene (Class C2 to BS 2869) and also bio-kerosene - up to a 30% blend (B30K).

All burner settings and nozzle sizes (as detailed in Section 2.3 of these instructions) are correct for both standard kerosene and bio-kerosene (B30K).

In order to operate this boiler on bio-kerosene, it will be necessary to take the following actions:

- Use a bio-kerosene (B30K) compatible flexible oil line in place of the oil line supplied with the boiler.
- Have the oil storage tank and oil supply line (including all pipework, sight gauges, filters, isolating valves, fire valves, de-aeration devices, etc.) checked for their compatibility with bio-kerosene (B30K).
Where necessary, some or all of these items may have to be replaced with a bio-kerosene compatible alternative.
- Check the suitability of the flue system with Grant UK.
- Use only bio-kerosene (B30K) that conforms to OPS24.

IMPORTANT:

Under no circumstances, should the boiler be used with bio-kerosene without the above actions being taken first.

! NOTE !

This appliance can be used by children aged from 8 years and above and persons with reduced physical, sensory or mental capabilities or lack of experience and knowledge if they have been given supervision or instruction concerning use of the appliance in a safe way and understand the hazards involved.

Children shall not play with the appliance. Cleaning and user maintenance shall not be made by children without supervision.

CONTENTS

1	INTRODUCTION	4	9	FLUE SYSTEM AND AIR SUPPLY	30
	1.1 How a condensing boiler operates	4		9.1 Air supply	30
	1.2 Boiler description	4		9.2 Plume diverter kit	30
	1.3 Flue options	4		9.3 Conventional flue systems	31
	1.4 Boiler components	5		9.4 External vertical conventional flue (Green System)	31
2	TECHNICAL DATA	6		9.5 External horizontal conventional flue (Green System)	33
	2.1 Boiler technical data	6		9.6 Flue clearances	34
	2.2 Sealed system data	6	10	COMMISSIONING	36
	2.3 Burner settings	7		10.1 Before switching on	37
	2.4 Flue gas analysis	7		10.2 Burner settings: RDB 2.2 BX burners	37
	2.5 Water connections	7		10.3 Air adjuster disc: 15/21 and 21/26 models only	39
	2.6 Boiler dimensions	8		10.4 Switching on	39
3	OIL STORAGE AND SUPPLY SYSTEM	9		10.5 Running the boiler	40
	3.1 Fuel supply	9		10.6 Balancing the system	40
	3.2 Burner oil connection	11		10.7 Completion	40
4	INSTALLATION	13		10.8 Information for the user	40
	4.1 Introduction	13	11	SERVICING	41
	4.2 Boiler location	13		11.1 Checks before servicing	41
	4.3 Regulations compliance	13		11.2 Dismantling prior to servicing	41
	4.4 Heating system design considerations	13		11.3 Cleaning the boiler	41
	4.5 Pipework materials	14		11.4 Cleaning the burner: RDB 2.2 BX burners	43
	4.6 Connections	14		11.5 Adjusting the diffuser	44
	4.7 Preparation for installation	14		11.6 Air adjuster disc: 15/21 and 21/26 models only	44
	4.8 Installing the boiler	15		11.7 Recommissioning	44
	4.9 Filling the heating system	15		11.8 Burner components	45
	4.10 Before you commission	15	12	FAULT FINDING	46
	4.11 Completion	15		12.1 Boiler fault finding	46
5	PIPE CONNECTIONS	16		12.2 Burner fault finding - Riello Burners	47
	5.1 Water connections	16	13	SPARE PARTS	48
	5.2 Water connections - sealed system models	16		13.1 Boiler parts list	48
	5.3 Water connections and thermostat phial positions	17		13.2 Sealed system parts list	48
6	CONDENSATE DISPOSAL	19		13.3 Riello RDB 2.2 BX burners	49
	6.1 General requirements	19	14	DECLARATION OF CONFORMITY	52
	6.2 Connections	19	15	HEALTH AND SAFETY INFORMATION	53
	6.3 Pipework	19		15.1 Insulation materials	53
	6.4 External pipework	19		15.2 Sealant and adhesive	53
	6.5 Condensate soakaway	20		15.3 Kerosene and Gas Oil fuels	53
	6.6 Condensate trap	20	16	END OF LIFE INFORMATION	54
	6.7 Condensate disposal pipework	21	17	PRODUCT FICHE	55
	6.8 Inspection and cleaning of trap	21	18	GUARANTEE	56
7	SEALED SYSTEMS	22	A1	WILO YONOS PARA RS RKC CIRCULATING PUMP	58
	7.1 Sealed system requirements	22	A2	WILO-PARA 25-130/7-50/SC-6#GRA CIRCULATING PUMP	60
	7.2 Filling the sealed system	23			
	7.3 Venting the pump	23			
	7.4 Pressure relief (safety) valve operation	23			
	7.5 System models	24			
8	ELECTRICAL	25			
	8.1 General	25			
	8.2 Connecting the power supply	25			
	8.3 Frost protection	26			
	8.4 Control system wiring diagrams	27			
	8.5 Boiler control panel wiring diagrams	29			

1 INTRODUCTION

1.1 HOW A CONDENSING BOILER OPERATES

During the combustion process, hydrogen and oxygen combine to produce heat and water vapour. The water vapour produced is in the form of superheated steam in the heat exchanger. This superheated steam contains sensible heat (available heat) and latent heat (heat locked up in the flue gas). A conventional boiler cannot recover any of the latent heat and this energy is lost to the atmosphere through the flue.

The Grant Vortex condensing boiler contains an extra heat exchanger which is designed to recover the latent heat normally lost by a conventional boiler. It does this by cooling the flue gases to below 90°C, thus extracting more sensible heat and some of the latent heat. This is achieved by cooling the flue gases to their dew point (approximately 55°C).

To ensure maximum efficiency, the boiler return temperature should be 55°C or less, this will enable the latent heat to be condensed out of the flue gases.

- The boiler will achieve net thermal efficiencies of 100%.

To achieve maximum performance from the Grant Vortex boiler, it is recommended that the heating system is designed so that a temperature differential of 20°C between the flow and return is maintained.

The Grant Vortex boiler will however still operate at extremely high efficiencies even when it is not in condensing mode and therefore is suitable for fitting to an existing heating system without alteration to the radiator sizes. The boiler is capable of a maximum flow temperature of 75°C.

1.2 BOILER DESCRIPTION

Grant Vortex Eco External modules have an insulated weatherproof enclosure made of galvanised steel with a powder coated finish, and are designed for external installation, either against a wall or free standing some distance away from the property, as required.

The Grant Vortex Eco range of automatic pressure jet oil boilers have been designed for use with a fully pumped central heating system with indirect domestic hot water cylinder.

They are not suitable for use with either a direct cylinder or a 'primatic' cylinder or gravity hot water.

The boilers are suitable for use on open vented or sealed central heating systems. System models are supplied with the necessary components factory fitted. Refer to Section 7.

All boilers are supplied with the control panel and burner factory fitted.

All the models in the current Grant Vortex Eco range of boilers are designed to comply with the maximum NOx emissions* under the Energy-related Products Directive (ErP).

* From the 26th September 2018, the maximum NOx emissions for all new oil fired boilers (up to and including 400kW for both new build and replacement boiler installations) is 120mg/kWh.

1.3 FLUE OPTIONS

Grant Vortex Eco External modules are supplied with a low level discharge flue system, which can either be fitted to the rear, left hand or right hand flue outlet position, as required.

It is possible to discharge the products of combustion at a higher level by using the following components from the Grant 'Green' flue system:

- External module starter (available as a straight section or with a 90° elbow, enabling the installer to use any flue outlet from the boiler casing)
- Fixed extensions 150mm, 250mm, 450mm and 950mm
- Adjustable extension 195 to 270mm
- 45° elbow
- High level 90° or vertical terminal

It is possible to extend the flue system by 19m vertically (from the boiler outlet) using this system.

Should the flue system need to navigate around objects, the green system can be used to horizontally extend the flue system by up to 3m from the centre of the boiler outlet.

Please note, the flue may either be brought up vertically from the boiler, or horizontally. Not a combination of the two.

Alternatively, the plume diverter kit, available from Grant UK, can be used to vertically extend the flue system.

Please see Sections 4.7 and 9 for more detailed instructions on how to install the flue system.

Conventional flues only may be fitted to Grant Vortex Eco External boilers.

! NOTE !

The flue system materials and construction MUST be suitable for use with oil-fired condensing boilers. Failure to fit a suitable conventional flue may invalidate the guarantee on the boiler.

1.4 BOILER COMPONENTS

All burners are pre-set for use with kerosene and are supplied ready to connect to a single pipe fuel supply system with a loose flexible fuel line and 3/8" to 1/4" BSP male adaptor supplied with the boiler.

If required, an additional flexible fuel line (900 mm in length, product code: RBS36 or 600mm in length, product code: RBS36XS) and 3/8" to 1/4" BSP male adaptor (product code: Z3003602) are available to purchase from Grant UK, for two-pipe oil supply systems.

The temperature of the water leaving the boiler to heat the radiators and hot water cylinder is user adjustable.

The boiler is fitted with an overheat thermostat (which allows it to be used on a sealed central heating system) which will automatically switch off the boiler if the heat exchanger exceeds a pre-set temperature of $110^{\circ}\text{C} \pm 3^{\circ}\text{C}$.

The control panel is fitted with an ON/OFF switch, boiler thermostat control knob and the manual reset button for the overheat thermostat.

Figure 1-1 shows the position and details of the control panel for the Vortex Eco External boiler.

1.4.1 BOILER CONTROLS

To access the control panel, remove the front door panel from the boiler. The controls on the panel are as follows:

Boiler On/Off switch

This switches the boiler on and off. The boiler ON/OFF switch incorporates a 'mains on' neon which lights when the boiler is switched on. Please note that the 'mains on' neon does not necessarily indicate that the burner is firing.

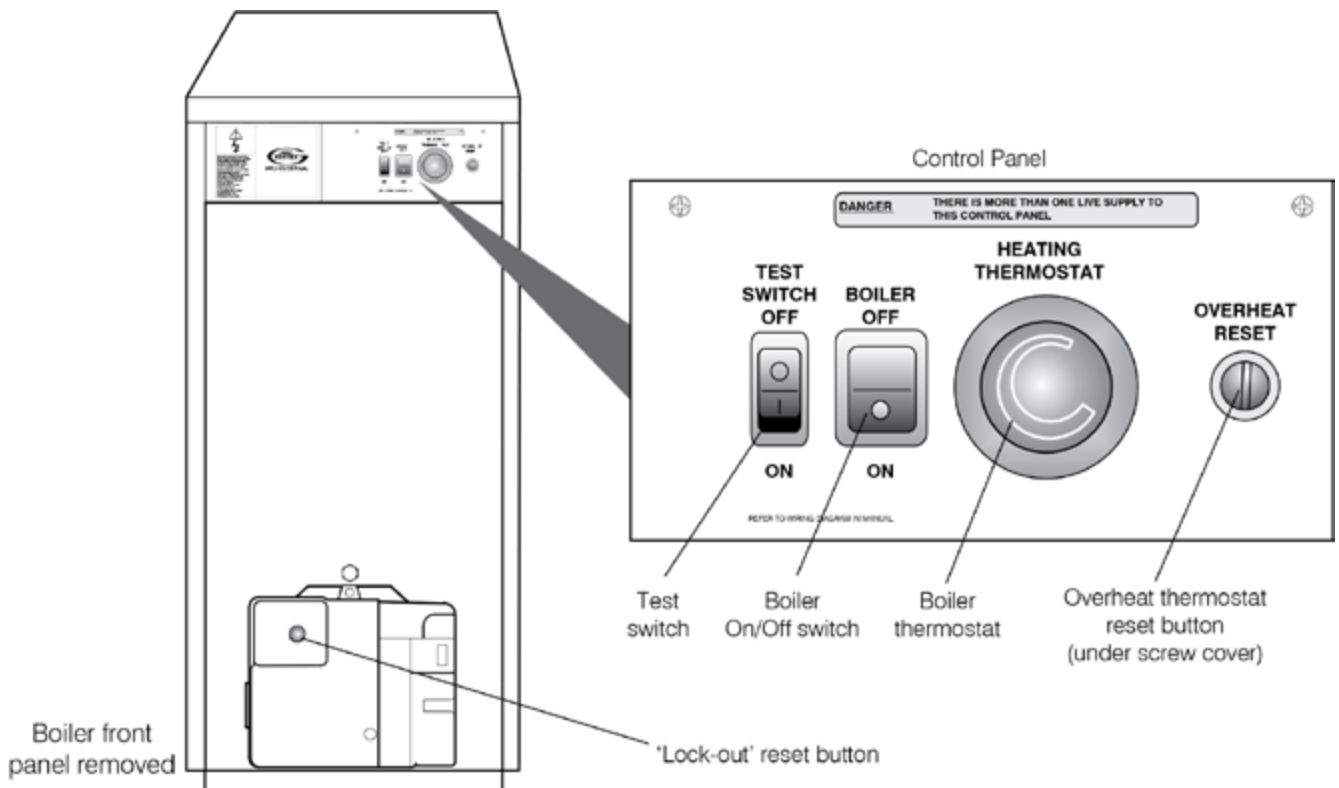

Figure 1-1: Vortex Eco External control panel

! NOTE !

If the ON/OFF switch is set to off the boiler will NOT supply central heating or heat domestic hot water (if a hot water cylinder is connected to the boiler). The built-in frost thermostat will also not operate.

Service/Test Switch (External Modules only)

A Service switch is fitted to the control panel to allow the Service Engineer to test-fire the boiler.

Heating Thermostat

This control allows the temperature of the water leaving the boiler to heat the radiators (and domestic hot water) to be adjusted. This will be set by the installer to the optimum temperature for efficient operation of the boiler. It should be left set in this position.

Overheat Thermostat (Overheat Reset)

The boiler is fitted with a safety overheat thermostat which will automatically switch off the boiler in the case of a control malfunction causing overheating.

2 TECHNICAL DATA

2.1 BOILER TECHNICAL DATA

Table 2-1: Boiler technical data

	Units	Eco External		
		15/21	21/26	26/35
Water content	litre	13	13	19
	gal	2.9	2.9	4.2
Weight (dry)	kg	113 (external module) 136 (external system)	113 (external module) 136 (external system)	142 (external module) 152 (external system)
	lb	249 (external module) 300 (external system)	249 (external module) 300 (external system)	313 (external module) 335 (external system)
Maximum heat output (Kerosene)	kW	21.0	26.0	35.0
	Btu/h	71,700	88,700	119,400
Minimum flow rate ($\Delta T=10^{\circ}\text{C}$)	l/h	1805	2,235	3,005
Minimum flow rate ($\Delta T=20^{\circ}\text{C}$)	l/h	902.5	1,117.5	1,502.5
Condensate connection		22 mm (only connect plastic pipe)		
Flue diameter (conventional)		100 mm		
Waterside resistance $\Delta T=10^{\circ}\text{C}$	mbar	28.5		
Waterside resistance $\Delta T=20^{\circ}\text{C}$	mbar	10.0		
Maximum static head	m	28		
Minimum circulating head	m	1		
Boiler thermostat range	$^{\circ}\text{C}$	50 to 75		
Limit (safety) thermostat shut off temperature	$^{\circ}\text{C}$	110 \pm 3		
Maximum hearth temperature	$^{\circ}\text{C}$	Less than 50		
Electricity supply		~230 1ph 50Hz 5A fused		
Burner motor power	Watts	90		
Absorbed motor power	kW	0.15		
Starting current	Amps	4.20		
Running current	Amps	0.85		
Oil connection		1/4" BSP male (on end of flexible fuel hose)		
Conventional flue draught	mbar	Minimum: 0.087 - Maximum: 0.37		
	in wg	Minimum: 0.035 - Maximum: 0.15		
Maximum operating pressure - sealed/open system	bar	2.0		
Maximum operating pressure - pressure relief valve	bar	3.0		
Boiler type		ON/OFF		

* 125 mm diameter required for flexible flue liner (Orange system). For rigid flue system, e.g. Green system, 100 mm diameter flue required. Refer to Section 9 (Flue System and Air Supply) for further details.

2.2 SEALED SYSTEM DATA

Table 2-2: Sealed System Data

	Eco System 15/21, 21/26 and 26/35
Heating system pressure (cold)	Maximum 1.0 bar Minimum 0.5 bar
Operating pressure of pressure relief valve	3.0 bar
Expansion vessel size (pre-charged at 1 bar)	12 litres (all models)
Maximum heating system volume (including boiler)*	131 litres (15/21 and 21/26) 125 litres (26/35) **
Cold water mains connection	15 mm copper pipe
Pressure relief valve discharge connection	15 mm copper pipe

* Based on vessel charge of 0.3 bar and system cold fill pressure of 0.5 bar. These values are the remaining system volume available after deducting the boiler water content.

** Approximately

2.3 BURNER SETTINGS

Table 2-3: Burner settings

Boiler models (burner type)	Heat output		Nozzle	Oil pressure (bar)	Smoke No.	Burner head type	Burner head/ air disc setting	Distance D ¹⁰ (mm)	Fuel flow rate (kg/h)	Flue gas temp. (°C)	CO ₂ (%)	Flue gas VFR ‡ (m ³ /hr)
	(kW)	(Btu/h)										
External 15/21 External System 15/21 (Riello RDB2.2 BX E15/21)	15.0	51,200	0.45/80°EH	7.5	0 - 1	BX 500	Disc: B	11	1.28	70 - 75	12.5	16.0
	18.0	61,400	0.55/60°ES	7.0	0 - 1	BX 500	Disc: C	11.5	1.53	75 - 80	12.5	20.0
	21.0 *	71,700	0.60/60°ES	8.0	0 - 1	BX 500	Disc: C	13	1.79	80 - 85	12.5	23.0
External 21/26 External System 21/26 (Riello RDB2.2 BX E21/26)	21.0	71,700	0.60/60°ES	8.0	0 - 1	BX 500	Disc: C	13	1.81	85 - 90	12.5	23.0
	23.5 *	80,200	0.65/60°ES	10.0	0 - 1	BX 500	Disc: C	13	2.02	85 - 90	12.5	26.0
	26.0	88,700	0.75/60°ES	8.5	0 - 1	BX 500	N/A	15	2.24	90 - 95	12.5	28.5
External 26/35 External System 26/35 (Riello RDB2.2 BX V26/36)	26.0	88,700	0.75/60°ES	8.5	0 - 1	BX 700	N/A	15	2.24	75 - 80	12.5	28.5
	31.0 *	105,800	0.85/60°ES	9.0	0 - 1	BX 700	N/A	16	2.67	85 - 90	12.5	34.5
	35.0	119,400	1.00/60°ES	8.5	0 - 1	BX 700	N/A	17.5	3.02	90 - 95	12.5	39.0

Notes:

‡ Flue gas VFR: Flue gas volumetric flow rate

- The data given above is approximate only and is based on the boiler being used with a low level balanced flue.
- The above settings may have to be adjusted on site for the correct operation of the burner.
- Gas Oil is NOT suitable for use with Grant Vortex boiler range
- The flue gas temperatures given above are ± 10%.
- When commissioning, the air damper **must be** adjusted to obtain the correct CO₂ level.
- * Factory settings: 15/21 - 21kW, 21/26 - 23.5kW, 26/35 - 31kW.
- The combustion door test point may be used for CO₂ and smoke readings only. Do not use this test point for temperature or efficiency readings.
- When setting the 15/21 to 15kW, the air adjuster disc requires repositioning. Refer to Section 10.3 (air adjuster disc).
When setting the 21/26 to 26kW, the air adjuster disc is not required. Refer to Section 10.3 (air adjuster disc).
- The installer must amend the boiler data label if the output is changed.
- Refer to Section 10.2 for information on how to set Distance D (Figure 10-5).

2.4 FLUE GAS ANALYSIS

To allow the boiler to be commissioned and serviced, the boiler is supplied with a combustion test point on the front cleaning door.

When this test point is used please note the following:

- The test point is for CO₂ and smoke readings only.
- The boiler efficiency and temperature must be taken from the flue test point on high level, vertical and conventional flue adaptors.
- Concentric low level flues do not contain a test point. The temperature and efficiency readings must be taken from the flue terminal.

2.5 WATER CONNECTIONS

Table 2-4: Water connections

Boiler model	Flow connection			Return connection		
	Size	Fitting	Supplied	Size	Fitting	Supplied
External 15/21 External System 15/21	22 mm pipe	Tectite elbow	In fittings kit	22 mm pipe	Compression	Fitted
External 21/26 External System 21/26	22 mm pipe	Tectite elbow	In fittings kit	22 mm pipe	Compression	Fitted
External 26/35 External System 26/35	22 mm pipe	Tectite elbow	In fittings kit	22 mm pipe	Compression	Fitted

2.6 BOILER DIMENSIONS

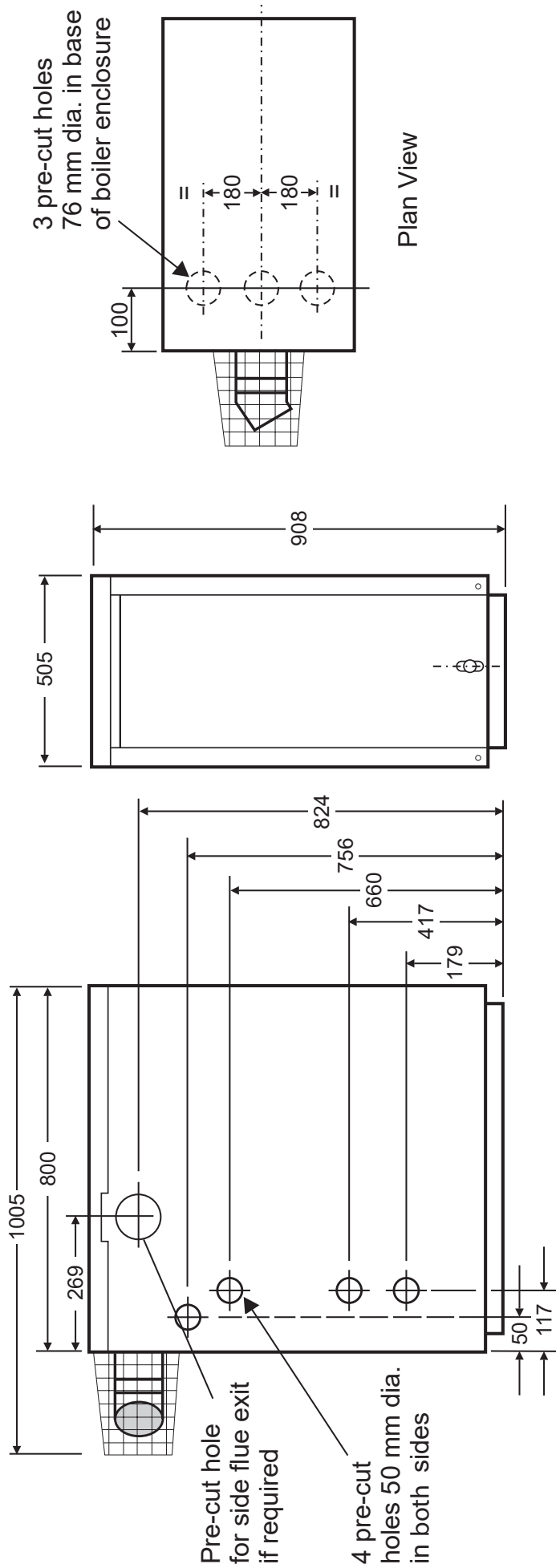

Figure 2-1: Vortex Eco External module dimensions (all models)

3 OIL STORAGE AND SUPPLY SYSTEM

3.1 FUEL SUPPLY

3.1.1 FUEL STORAGE

The tank should be positioned in accordance with the recommendations given in BS 5410-1 (Code of practice for liquid fuel firing. Installations for space heating and hot water supply purposes for domestic buildings). This gives details of the requirements for suitable oil tank construction, tank installation, tank bases, fire protection and secondary containment.

For installations of greater than 70kW output capacity, the tank should be installed accordance with BS 5410-2.

Oil storage tanks should comply with the following standards:

- Plastic tanks OFT T100
- Steel tanks OFT T200

! CAUTION !

A galvanised tank must not be used.

! NOTE !

Plastic tanks should be stood on a firm non-combustible base that adequately and uniformly supports the weight of the tank over its entire base area.

The tank capacity should be selected to suit the appliance rated output. Refer to BS5410-1 for guidance.

3.1.2 FUEL PIPES

Fuel supply pipes should be either copper or steel. Galvanised pipes or fittings should not be used.

Plastic oil supply pipe conforming to BS EN 14125 can be used for underground pipe runs, but must not be used above ground.

All soft copper pipe connections should preferably be made using flared fittings. If compression fittings are to be used, a suitable pipe insert must be fitted into the pipe end.

Soft soldered connections must NOT be used on oil supply pipework.

Fuel supply pipework should be of a suitable diameter, depending on the type of oil supply system being used. Refer to information given in sections 3.1.3, 3.1.4 or 3.1.5.

Run pipes as level as possible to prevent air being trapped. Take the most direct route possible from tank to burner whilst locating the pipe where it will be protected from damage.

Pipes should be supported to prevent sagging and sleeved where they pass through a wall.

A metal body fuel filter with a filtration size of no more than 50 µm (micron) must be fitted in the oil supply pipe close to the tank. This should be fitted with sufficient clearance around and below it to allow easy access for maintenance.

An isolating valve should also be fitted at the tank, before the filter, to allow the oil supply to be shut off for the filter to be serviced.

A second filter (15 µm for Kerosene) must be located closer to the burner to protect the burner pump and nozzle from contamination. Refer to Figures 3-1 to 3-3.

A remote sensing fire valve must be installed in the fuel supply line in accordance with BS5410-1.

A fusible wheelhead type combined isolating/fire valve MUST NOT be used in place of a remote sensing fire valve.

The fire valve must be located externally to the appliance casing, with the fire valve sensor located above the burner.

A spring clip for mounting the sensor is supplied fitted to the boiler, on the rear of the control panel.

The fire valve should be located after the second (15 micron) filter, i.e. between the filter and the point at which the oil line enters the appliance casing. Refer to Figures 3-1 to 3-3.

The fire valve must have an operating temperature of between 90 and 95°C to avoid unnecessary nuisance shut-offs to the oil supply.

A flexible fuel hose and ¼" isolating valve are supplied loose with the boiler, to make the final connection to the burner.

If a two-pipe system or deaerator is to be used, the following additional items will be required:

- Flexible fuel hose ¾" male x ¼" female (product code: RBS36 - 900 mm / product code: RBS36XS - 600mm)
- ¾" x ¼" BSP adaptor (product code: Z3003602)
- ¼" isolating valve (product code: ISOLATION1/4)

These are available to purchase from Grant UK.

Metal braided flexible fuel hoses should be replaced ANNUALLY when the boiler is serviced.

Long life flexible fuel hoses should be inspected annually and replaced, if necessary, or after a maximum five years service life.

Flexible fuel hoses MUST NOT be used outside of the appliance casing.

3.1.3 SINGLE PIPE (GRAVITY) SYSTEM - (REFER TO FIGURE 3-1)

Head A (m)	Maximum pipe run (m)	
	10 mm OD pipe	12 mm OD pipe
0.5	10	20
1.0	20	40
1.5	40	80
2.0	60	100

If the storage tank outlet is at least 300 mm above the level of the burner oil pump, a single pipe (gravity) system should be used.

The maximum height of the oil level above the burner oil pump when the tank is full, must not exceed four metres. If this height is exceeded, a pressure reducing valve must be fitted in the oil supply pipe between the tank and the burner oil pump.

The maximum length of pipe run from the tank to the burner is limited by the minimum head of oil (the height of the tank outlet above the burner oil pump).

3.1.4 TWO PIPE SYSTEM - (REFER TO FIGURE 3-2)

Head A (m)	Maximum pipe run (m)	
	10 mm OD pipe	12 mm OD pipe
0	35	100
0.5	30	100
1.0	25	100
1.5	20	90
2.0	15	70
3.0	8	30
3.5	6	20

If the storage tank outlet is below the level of the burner oil pump, a two pipe (sub gravity) system can be used.

The return pipe should be at the same level as the tank outlet, between 75 to 100 mm above the base of the tank. The return pipe should be a sufficient distance from the tank outlet so as to prevent any sediment disturbed by the return entering the supply pipe from the tank.

A non-return valve should be fitted in the supply pipe, along with a fire valve and filters (refer to section 3.1.2 - fuel pipes). A non-return valve should also be fitted in the return pipe if the top of the tank is above the burner oil pump.

The maximum suction height (from the tank outlet to the level of the burner oil pump), must not exceed 3.5 metres.

The pump vacuum should not exceed 0.4 bar. Beyond this limit, gas is released from the oil.

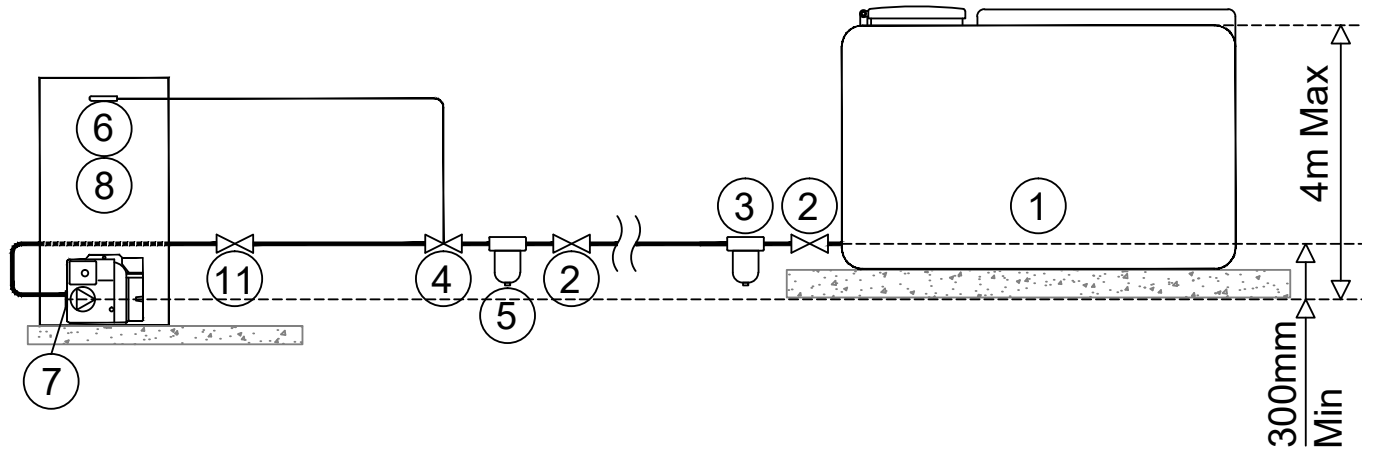

Figure 3-1: Single pipe (gravity) system

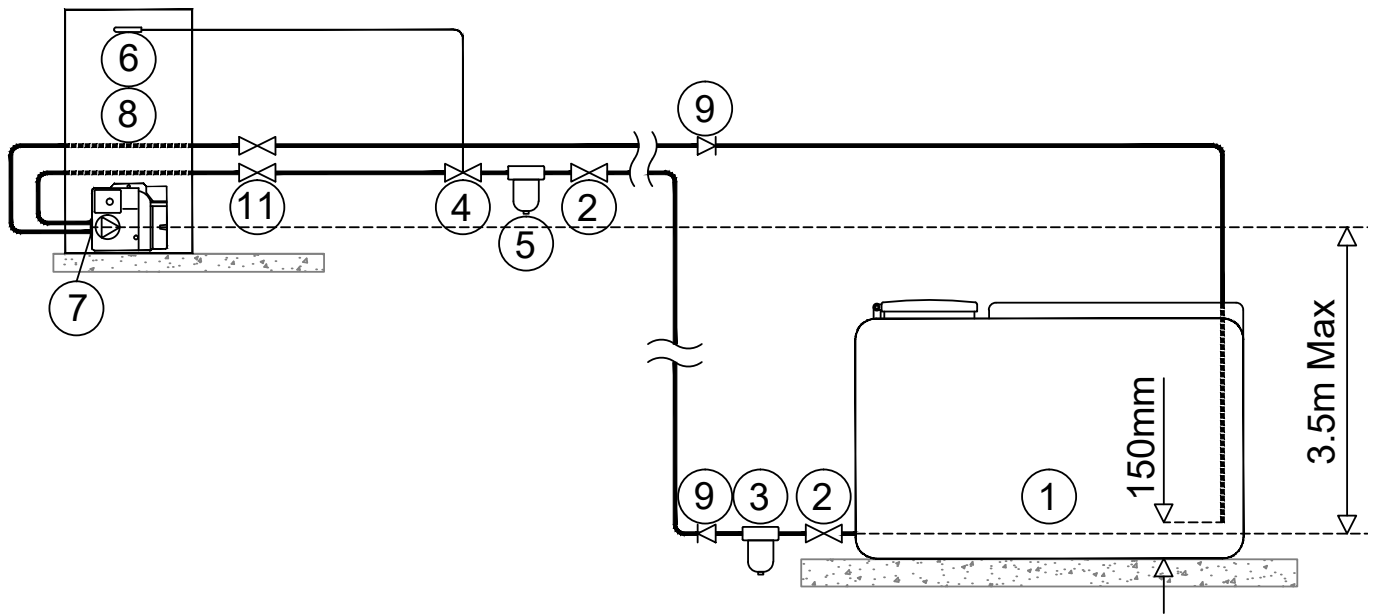

Figure 3-2: Two pipe system

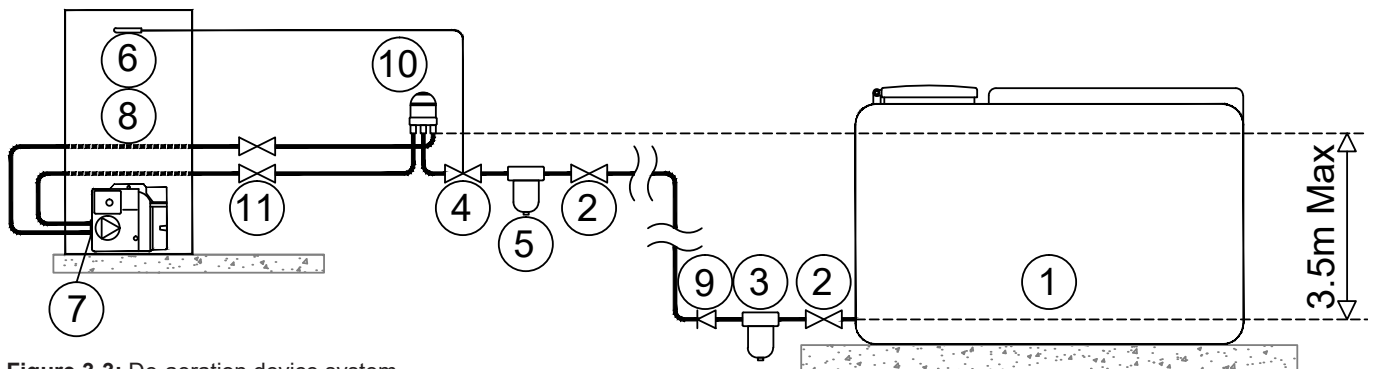

Figure 3-3: De-aeration device system

Key to oil supply diagrams

1	Oil tank	5	Oil filter (15µm max. filtration size)	9	Non-return valve
2	Isolating valve	6	Fire valve sensor	10	De-aerator*
3	Oil strainer	7	Oil pump	11	Appliance isolation valves
4	Fire valve to BS5410-1	8	Burner		

* Position of de-aeration device must be level with or above the oil pump

For guidance on the installation of top outlet fuel tanks and suction oil supply pipe sizing, refer to OFTEC Technical Book 3: Storage and Supply, available for purchase from OFTEC.

If a two-pipe system is to be used, the following additional items will be required:

- Flexible fuel hose 3/8" male x 1/4" female (product code: RBS36 - 900 mm / product code: RBS36XS - 600mm)
- 3/8" x 1/4" BSP adaptor (product code: Z3003602)
- 1/4" isolating valve (product code: ISOLATION1/4)

These are available to purchase from Grant UK.

3.1.5 SINGLE PIPE (SUCTION) SYSTEM WITH DEAERATOR - (REFER TO FIGURE 3-3)

If the storage tank outlet is below the level of the burner oil pump, an alternative to the two pipe (sub gravity) system is the single pipe (suction) system using a deaerator, e.g. a 'Tiger Loop' device.

The deaerator creates a loop with the burner oil pump, with the oil being circulated through the pump out to the deaerator and back to the pump. Any air in the single pipe lift from the tank is removed from the oil, collected in the deaerator and then discharged to outside.

! WARNING !

To prevent any fuel vapour being discharged within the building, the deaerator must be fitted outside, in accordance with BS 5410-1, unless it is specifically designed to be installed inside.

The de-aerator must be mounted vertically at the same level as (or above) the burner oil pump. Refer to Figure 3-3.

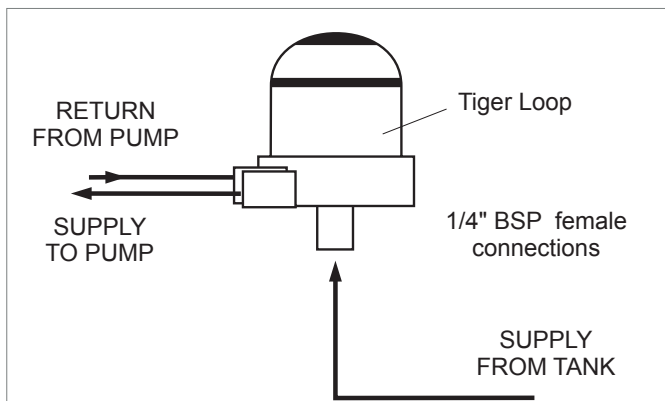

Figure 3-4: Tiger loop de-aeration device

An external deaerator must not be fitted within 500 mm of a flue terminal.

Always follow the manufacturers installation instructions supplied with the deaerator.

To use a de-aerator, the following additional items will be required:

- Flexible fuel hose 3/8" male x 1/4" female (product code: RBS36 - 900 mm / product code: RBS36XS - 600mm)
- 3/8" x 1/4" BSP adaptor (product code: Z3003602)
- 1/4" isolating valve (product code: ISOLATION1/4)

These are available to purchase from Grant UK.

3.2 BURNER OIL CONNECTION

! WARNING !

The blanking plug supplied in the inlet (suction) port is plastic and will not provide an oil tight seal when the pump is running.

Ensure that the supply from the tank is connected to this port and that the plastic plug is discarded.

The burner fuel pump is supplied factory set for use with a single pipe (gravity) oil supply system.

For ease of access to the burner oil pump connections, the burner should be removed from the boiler as follows:

1. Remove the red plastic burner cover.
 - Unscrew and remove the TWO fixing screws from the red burner cover and remove the cover from the burner.
2. Unscrew and remove the single burner fixing nut from the stud on the burner flange (at the top of the burner) using a 13 mm spanner. Retain the fixing nut for re-fitting the burner.
3. Carefully withdraw the burner from the boiler.

3.2.1 SINGLE PIPE (GRAVITY) CONNECTION - REFER TO FIGURE 3-5

Connect the oil supply to the burner oil pump as follows:

1. Unscrew and remove the plastic blanking plug from the suction port of the burner oil pump and discard it.
2. Fit the nut of the elbow connection on the flexible fuel hose (supplied with the boiler) into the suction port and tighten.
3. Fit the 1/4" isolating valve (supplied with the boiler) to the end of the rigid oil supply pipe using a fitting to suit the pipe size and type (not supplied).
4. Connect the other end of the flexible fuel hose to the isolating valve using the 3/8" x 1/4" BSP adaptor (supplied with the boiler).
5. Re-fit the burner to the boiler.

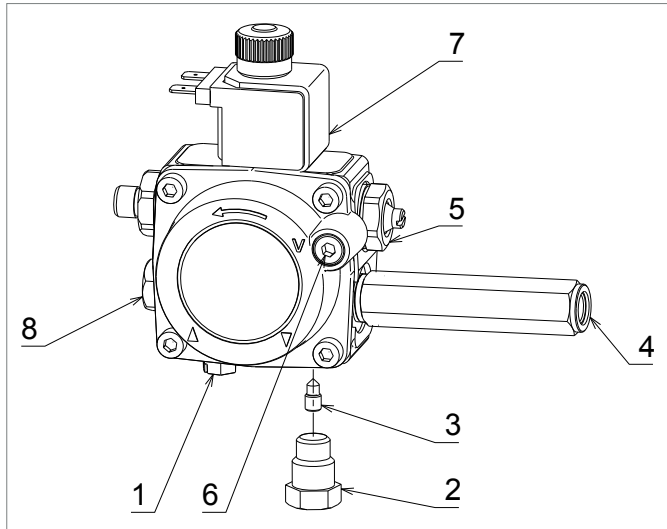

Figure 3-5: Riello oil pump

Item	Description
1	Inlet (suction) port
2	Return port
3	By-pass screw
4	Pressure gauge port
5	Pressure adjustment
6	Vacuum gauge port
7	Solenoid
8	Auxiliary pressure test point

3.2.2 TWO PIPE CONNECTION

For either a two pipe (sub gravity) or a single pipe (suction) system with a deaerator, the following additional items will be required:

- Flexible fuel hose 3/8" male x 1/4" female (product code: RBS36 - 900 mm / product code: RBS36XS - 600mm)
- 3/8" x 1/4" BSP adaptor (product code: Z3003602)
- 1/4" isolating valve (product code: ISOLATION1/4)

These are available to purchase from Grant UK.

Connect the oil supply to the burner oil pump as follows:

1. Fit the flexible fuel hose (supplied with the boiler) to the suction port of the burner oil pump, as detailed in Section 3.2.1.

With either a two pipe (sub gravity) system or a single pipe (suction) system with a deaerator, the by-pass screw (supplied with the boiler) must be fitted to the burner oil pump as follows:

1. Unscrew and remove the blanking plug from the return port on the burner oil pump and discard it.
2. Fit the by-pass screw into the threaded hole (inside the return port) and fully screw it in using an Allen key.
3. Fit the nut of the elbow connection on the flexible fuel hose into the return port and tighten.
4. Fit the 1/4" isolating valve (not supplied) to the end of the rigid oil return pipe (to the deaerator or oil tank) using a fitting to suit the pipe size and type (not supplied).
5. Connect the other end of the flexible fuel hose (not supplied) to the isolating valve using a 3/8" x 1/4" BSP adaptor (not supplied).
6. Re-fit the burner to the boiler.

4 INSTALLATION

4.1 INTRODUCTION

The boiler is supplied already fully assembled, with the flue terminal guard loose inside the boiler, in a carton which is carefully packed with packing materials. The installation procedure therefore begins with unpacking of the packed boiler.

4.2 BOILER LOCATION

The External module must stand on a firm and level surface capable of supporting the boiler when full of water. Refer to Section 2.1 for weights.

It does not require a special hearth as the temperature of the boiler base is less than 50°C.

The module can be installed either against the building, or 'free standing' some distance away from the building.

Sufficient clearance must be allowed at the front of the boiler to remove the burner and baffles for servicing, clearance must also be left at the top of the module to allow removal of the top panel.

Adequate clearance is also required at the rear of the module, to allow removal of the back panel for access to the condensate trap.

4.3 REGULATIONS COMPLIANCE

! NOTE !

Failure to install and commission appliances correctly may invalidate the boiler guarantee.

Installation of a Grant Vortex boiler must be in accordance with the following recommendations:

- Building Regulations for England and Wales, and the Building Standards for Scotland issued by the Department of the Environment and any local Byelaws which you must check with the local authority for the area.
 - Model and local Water Undertaking Byelaws.
 - Applicable Control of Pollution Regulations.
 - National Building Regulations and any local Byelaws.
 - Model Byelaws and the Water Supply Regulations.
 - The following OFTEC requirements:
 - OFS T100 Polythene oil storage tanks for distillate fuels.
 - OFS T200 Fuel oil storage tanks and tank bunds for use with distillate fuels, lubrication oils and waste oils.
- Further information may be obtained from the OFTEC Technical Book 3 (Installation requirements for oil storage tanks) and OFTEC Technical Book 4 (Installation requirements for oil fired boilers).

The installation should also be in accordance with the latest edition of the following British Standard Codes of Practice (and any relevant amendments):

- BS 5410-1: 2019 (Code of practice for liquid fuel firing. Installations for space heating and hot water supply purposes for domestic buildings)
 - This standard covers domestic installations up to 70kW.
- BS 5410-2: 2018 (Code of practice for liquid fuel firing. Non-domestic installations)
 - This standard should be followed with regard to installations with an output capacity in excess of 70kW.
 - Where the combined outputs of multiple appliances located together at a domestic dwelling exceed 70kW then a dedicated plant room as specified in BS 5410-2 is recommended.
- BS EN 12828 (Heating systems in buildings. Design for water-based heating systems)
- BS EN 12831-1 (Energy performance of buildings. Method for calculation of the design heat load)

- BS EN 14336 (Heating systems in buildings. Installation and commissioning of water based heating systems)
- BS 7593 (Code of Practice for treatment of water in domestic hot water central heating systems)
- BS 7671 (Requirements for Electrical installations, IET Wiring Regulations)
- BS 7291 (Thermoplastics pipe and fitting systems for hot and cold water for domestic purposes and heating installations in buildings. General requirements)
- BS 7074-1 (Application, selection and installation of expansion vessels and ancillary equipment for sealed water systems. Code of practice for domestic heating and hot water supply)
- BS 2869 (Fuel oils for agricultural, domestic and industrial engines and boilers. Specification)

! WARNING !

BS5410-1: 2019 requires that appliances located in a building or structure or within a restricted area externally should have a CO detector conforming to BS EN 50291-1 installed in the same room/space.

4.4 HEATING SYSTEM DESIGN CONSIDERATIONS

! WARNING !

Before starting any work on the boiler or fuel supply, please read the Health and Safety information given in Section 15.

To achieve the maximum efficiency possible from the Grant Vortex boiler, the heating system should be designed to the following parameters:

RADIATORS:

- Flow temperature 70°C
- Return temperature 50°C
- Differential 20°C

Size radiators with a mean water temperature of 60°C.

Design system controls with programmable room thermostats or use weather compensating controls to maintain return temperatures below 55°C.

! NOTE !

The boiler should not be allowed to operate with return temperatures of less than 40°C when the system is up to temperature.

The use of a pipe thermostat is recommended to control the return temperature when using weather compensating controls.

UNDERFLOOR:

- Flow temperature 50°C
- Return temperature 40°C
- Differential 10°C

In underfloor systems, it is essential that the return temperature must be maintained at or above 40°C to prevent internal corrosion of the boiler water jacket.

Refer to Section 2.5 for the size and type of the connections and Section 5 for the position of the connections.

OPEN VENTED SYSTEMS:

! NOTE !

The presence of 'pumping over' in an open vented heating system connected to the Grant Vortex boiler will invalidate the product guarantee.

Open vented systems must be correctly designed and installed. The open safety vent pipe must be positioned to prevent 'pumping over' (i.e. the discharge of water from the open safety vent pipe into the feed and expansion cistern under the pressure created by the circulator). For detailed information on the correct design of open vented heating systems, and the correct location of the open safety vent pipe, refer to the CIBSE Domestic Heating Design Guide and OFTEC Technical Book 4 (Installation).

4.5 PIPEWORK MATERIALS

The Grant Vortex boiler is compatible with both copper and plastic pipe. Where plastic pipe is used it must be of the oxygen barrier type and be the correct class (to BS 7291-1) for the application concerned.

On either sealed or open-vented systems; where plastic pipe is used a minimum of ONE metre of copper pipe (or as per pipe manufacturers instructions) MUST be connected between both the boiler flow and return connections and the plastic pipe.

! NOTE !

Do not connect plastic pipe directly to the boiler.

Grant UK does not accept any responsibility for any damage, however caused, to plastic piping or fittings.

SEALED SYSTEMS

If plastic pipe is to be used, the installer must check with the plastic pipe manufacturer that the pipe to be used is suitable for the temperature and pressures concerned.

Plastic pipe must be Class S to BS 7291-1.

! WARNING !

When plastic pipe is used, the system MUST incorporate a low pressure switch to shut off power to the boiler if the system pressure drops below 0.2 bar. A suitable low pressure switch kit is available to purchase from Grant UK (product code: MPCBS62).

UNDERFLOOR PIPEWORK

Plastic pipe may be used on underfloor floor systems where the plastic pipe is fitted after the thermostatic mixing valve. Copper tube must be used for at least the first metre of flow and return primary pipework between the boiler and the underfloor mixing/blending valves.

4.6 CONNECTIONS

4.6.1 FLOW AND RETURN CONNECTIONS

Refer to Section 5.

4.6.2 CONDENSATE CONNECTION

Grant Vortex Eco boilers are supplied with a factory-fitted condensate trap to provide the required 75 mm water seal in the condensate discharge pipe from the boiler.

Refer to Section 6 for details of the condensate disposal pipework.

4.6.3 DRAIN COCK

A drain cock is fitted at the bottom on the front of the boiler to allow the heating system to be drained.

4.7 PREPARATION FOR INSTALLATION

1. Carefully remove the packaging from the boiler and remove it from the transit pallet.
2. Remove the case top panel (four screws) and also the front and rear panels as required.
3. The flue may exit the boiler from the left, right or rear of the casing. Carefully press out the pre-cut section on the side or rear casing panel to provide the opening in the required position for the flue to pass through the casing.
Fit the cover panel (with the round flue exit hole) over the chosen opening in the casing. Fit the circular rubber sealing grommet provided into the circular hole in the cover panel before fitting the flue terminal section (or first flue extension if the flue is being extended using the green system).
4. Slacken the wing nuts holding the starter elbow and rotate the elbow to the required direction for the flue to exit the casing.
5. Push the end of the flue terminal section or flue extension (with the red seal) from the outside of the boiler casing through the sealing grommet in the casing panel. The terminal section has been factory lubricated. Take care not to dislodge or damage the red flue seal.

If using the low level flue option provided with the boiler:

6. Carefully insert the terminal into the starter elbow until the bend of the terminal contacts the outer casing, then pull the terminal forward approximately 25mm and rotate the bend so that the outlet is **horizontal**.

Rear Exit - The flue must discharge away from the building.

Side Exit - The flue should discharge towards the rear of the casing to prevent flue gases re-entering the boiler casing through the air inlet vents on the casing door.

The flue terminal must be fitted horizontally to prevent dripping from the end of the terminal.

If you are planning to extend the flue before terminating:

7. Carefully insert the first extension/elbow piece into the starter elbow and secure with a locking band.
8. Tighten the wing nuts holding the starter elbow and fit the stainless steel flue guard (if using low level flue option provided with boiler) using the two screws provided.
9. The top panel of the casing has been designed so that it may be fitted to create a slight slope away from the side positioned against the wall. To tilt the top panel, loosen the four top panel casing screws and push down on the side furthest from the wall. Tighten the screws. See Figure 4-1.

4.8 INSTALLING THE BOILER

1. If the boiler is to be fitted against a wall, prepare the wall to accept the heating system pipework. To mark the wall for drilling, refer to Section 2.6 for the positions of the pipework openings in the enclosure sides.

! NOTE !

Pipework should be insulated where it passes through the wall into the boiler enclosure.

- If the boiler is to be installed 'free standing' (i.e. away from a wall) and the pipework run underground, push out the 'knock-outs' to open the required pipe openings in the base of the boiler enclosure. Using a sharp knife, cut through the polystyrene in the base, around the edge of the holes, to allow the flow and return pipes to enter the enclosure.
2. The electrical supply to the boiler should be routed through the wall in a suitable conduit, such that it enters the boiler enclosure via one of the unused pipework openings. The cable can be routed to the front of the boiler, for connection to the boiler control panel, either over the top or beneath the boiler heat exchanger. Heat resistant PVC cable, of at least 0.75mm² cross section should be used within the boiler enclosure. Refer to Section 8 for further information regarding the electrical side of the installation process.

! NOTE !

Pipework and cables can be routed into the enclosure via one of the unused flue exit holes by using a section of 110mm soil pipe as ducting through the wall. The flue exit holes in the boiler casing are sized to accept 110mm soil pipe.

3. The oil supply line should be installed up to the position of the boiler. Refer to section 3.1 for details. The final connection into the boiler enclosure can be made with 10mm soft copper, routed along the base of the enclosure (either between the enclosure and wall or in front of the enclosure) to enter through one of the holes located in the bottom edge side panel, at the front (burner) end.
4. Connect the power supply as described in Section 8.
5. Ensure the flue terminal position complies with the necessary clearances outlined in Section 9.

4.9 FILLING THE HEATING SYSTEM

Refer to Section 7.2 (Filling the Sealed System)

4.10 BEFORE YOU COMMISSION

To avoid the danger of dirt and foreign matter entering the boiler the complete heating system should be thoroughly flushed out – both before the boiler is connected and then again after the system has been heated and is still hot. This is especially important where the boiler is to be installed on an older system.

For optimum performance after installation, the boiler and the associated heating system must be flushed in accordance with the guidelines given in BS 7593 (Treatment of water in domestic hot water central heating systems). This must involve the use of a proprietary cleaner, such as Sentinel X300 (new systems), Sentinel X400 (existing systems), or Fernox Restorer.

After cleaning, it is vitally important that all traces of the cleaner are thoroughly flushed from the system.

For long term protection against corrosion and scale, after cleaning/flushing a suitable inhibitor should be added to the system water, such as Sentinel X100 or Fernox MB-1, in accordance with the manufacturers' instructions.

Failure to follow the above will invalidate the guarantee.

If the boiler is installed in a garage, out house or outside, in order to provide further protection should there be a power failure in cold weather, a combined anti-freeze and corrosion inhibitor can be used such as Sentinel X500 or Fernox Alpha-11. Follow the manufacturers' instructions supplied to achieve the level of anti-freeze protection required.

For details of the Sentinel Products visit www.sentinel-solutions.net and for Fernox products visit www.fernox.com.

Grant UK strongly recommends that a Grant Mag One in-line magnetic filter/s (or equivalent*) is fitted in the heating system pipework. This should be installed and regularly serviced in accordance with the filter manufacturer's instructions.

* As measured by gauss. The MagOne magnetic filter has a gauss value of 12000.

4.11 COMPLETION

Following installation of the boiler, instruct the user in the operation of the boiler, the boiler controls, the heating controls and the safety devices.

Please ensure that the OFTEC CD/10 installation completion report (provided with the boiler) is completed in full, leaving the top copy with the user and retain the carbon copy for your own records.

Ensure that the User Handbook (supplied with the boiler) is handed over to the user.

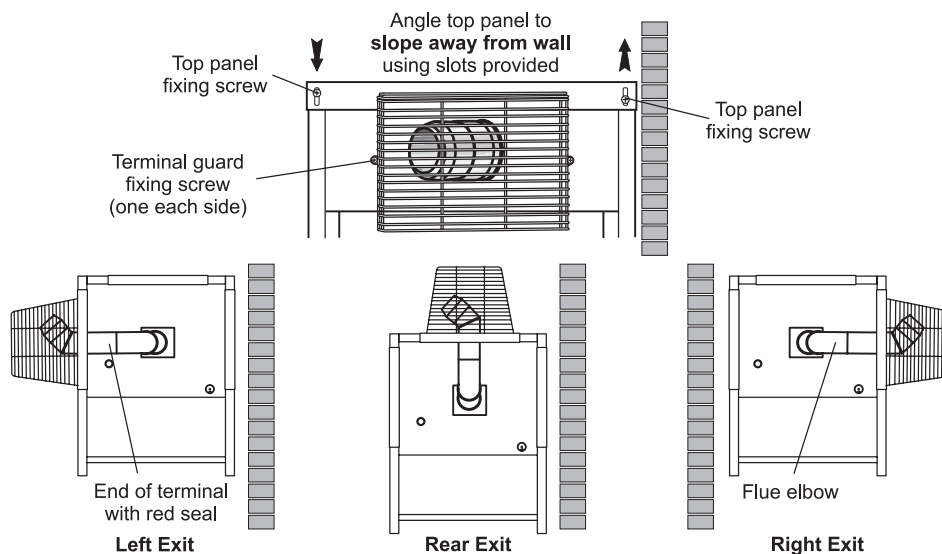

Figure 4-1: Standard low level flue provided with Outdoor Module

5 PIPE CONNECTIONS

5.1 WATER CONNECTIONS

The flow and return pipework can exit the boiler enclosure either through the pre-cut openings provided in both sides (under the movable cover plates) and through the wall when installed against the building, down and through the pre-cut openings provided in the base of the enclosure for 'free standing' installations, or through an unused side flue exit opening (the flue exit holes in the side of the boiler casing are sized to accept a 110mm soil pipe to be used as a pipe duct through the wall). See Section 2.6.

Push out the 'knock-out' from the required holes, taking care not to distort the side panel or base.

For condensate disposal pipework refer to Section 6.

1. To gain access to the water connections, remove the two screws securing the bottom of the back panel and remove it by withdrawing it forwards at the bottom. Remove the top casing panel.
2. Fit the flue starter elbow in the chosen position. This should be done at this point to ensure the starter elbow will not conflict with any of the pipework. Refer to Sections 4.7 and 9.
3. Carefully manoeuvre the boiler in position to line up with pipework through the wall. Complete the water connections. **Note:** Check that the baffles are in position and that the cleaning cover is correctly fitted and a good seal made.
4. If the boiler is installed against a wall, fit the wall flashing strip. Position the strip with the bottom edge of the wider flange 20 mm above the enclosure top panel, with the narrow flange (with the three fixing holes) flat against the wall. The strip should overhang the top panel by an equal amount at each end.
5. Mark the position of the three fixing holes onto the wall, drill and plug the wall and secure the strip with suitable screws (not supplied).

Flow connection: A 22 mm pipe is provided for the flow connection. This is located on the top of the boiler. The pipe will need to be vented, as it is the highest point on the primary heat exchanger.

Return connection: A 22 mm pipe is provided for the return connection. This is located on the top of the boiler. The pipe will also need to be vented at some point, as it is the highest point on the secondary heat exchanger.

! CAUTION !

All pipes to be fitted into the push-fit connectors provided should be cut using a pipe slicer or pipe cutter - to leave the pipe ends with a slight radius and free from any burrs or sharp edges. Pipes to be used with these fittings should not be cut square using a hacksaw.

5.2 WATER CONNECTIONS - SEALED SYSTEM MODELS

A 15 mm discharge pipe must be connected to the safety valve outlet connection. The pipework between the safety valve and the boiler must be unrestricted, that is, no valves. The discharge pipe should be run to the outside of the building and terminate so that it cannot cause injury to persons or property. Refer to Section 7 for further guidance.

A 15 mm double check valve ballofix type valve is provided on the flexible filling loop hose for connection of the cold mains supply to the heating system.

The cold mains supply should terminate inside the boiler casing.

A drain cock is fitted at the bottom on the front of the boiler to allow the heating system to be drained.

The expansion vessel is connected via a flexible hose to allow it to be moved to gain access to other components for servicing.

When replacing the vessel, care should be taken to ensure that the flexible connecting hose is not twisted.

! NOTE !

For guidance on the connection of the heating system pipework, please refer to Sections 4.7, 4.8, 5.1 and 7.

5.3 WATER CONNECTIONS AND THERMOSTAT PHIAL POSITIONS

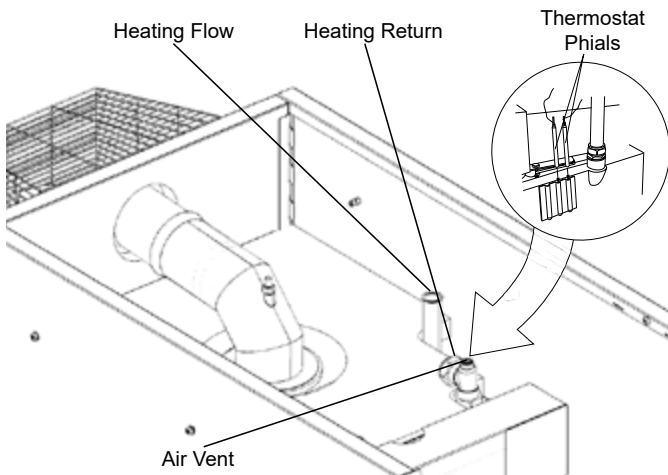

Figure 5-1: Vortex Eco External 15/21 and 21/26 water connections and thermostat phial positions

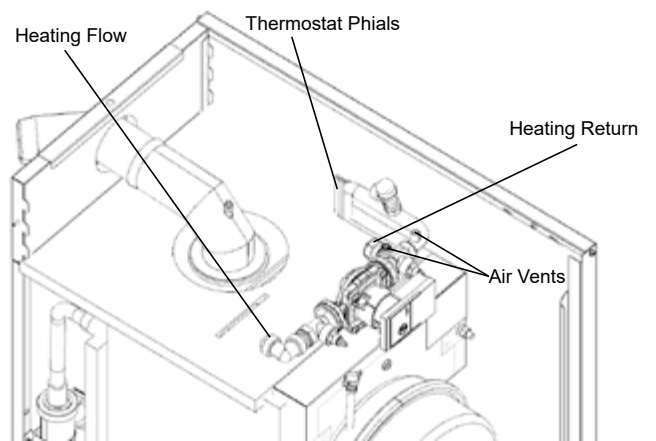

Figure 5-3: Vortex Eco External System 15/21 and 21/26 water connections and thermostat phial positions

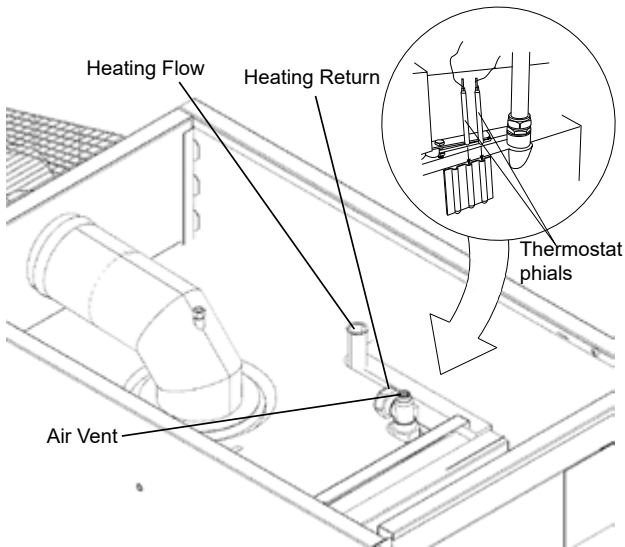

Figure 5-2: Vortex Eco External 26/35 water connections and thermostat phial positions

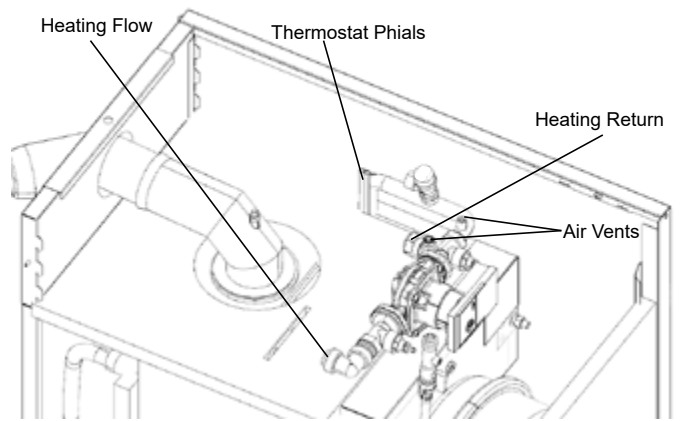

Figure 5-4: Vortex Eco External System 26/35 water connections and thermostat phial positions

Page intentionally left blank.

6 CONDENSATE DISPOSAL

6.1 GENERAL REQUIREMENTS

When in condensing mode the Grant Vortex boilers produce condensate from the water vapour in the flue gases.

This condensate is moderately acidic with a pH value of around 3.27 (similar to orange juice).

Provision must be made for the safe and effective disposal of this condensate.

Condensate can be disposed of using one of the following methods of connection:

Internal connection (preferred option)

- into an internal domestic waste system (from kitchen sink, washing machine, etc.)
- directly into the soil stack

External connection

- into an external soil stack
- into an external drain or gully
- into a rainwater hopper (that is part of a combined system where sewer carries both rainwater and foul water)
- purpose made soakaway

All condensate disposal pipes **must** be fitted with a trap - whether they are connected internally or externally to a domestic waste system/soil stack or run externally to a gully, hopper or soakaway.

6.2 CONNECTIONS

Connections into a rainwater hopper, external drain or gully should be terminated inside the hopper/drain/gully below the grid level but above the water level.

! CAUTION !

Condensate disposal pipes must not be connected directly into rainwater downpipes or to waste/soil systems connected to septic tanks.

Condensate should not be discharged into 'grey water' systems that re-use water used in the home (not including water from toilets).

It should be noted that connection of a condensate pipe to the drain may be subject to local Building Control requirements.

6.3 PIPEWORK

Condensate disposal pipework must be plastic (plastic waste or overflow pipe is suitable).

! NOTE !

Copper or steel pipe is NOT suitable and MUST NOT be used.

Condensate disposal pipes should have a minimum 'nominal' diameter of 22 mm (¾") - e.g. use 21.5 mm OD polypropylene overflow pipe.

Condensate disposal pipes must be fitted with a fall (away from the boiler) of at least 2.5° (~45 mm fall per metre run).

! NOTE !

Where it is not possible for the pipe to fall towards the point of discharge - either internally into a waste system or externally to a gully (e.g. for boilers installed in a basement), it will be necessary to use a condensate pump.

Condensate disposal pipes should be kept as short as possible and the number of bends kept to a minimum.

Pipes should be adequately fixed to prevent sagging, i.e. at no more than 0.5 metre intervals.

6.4 EXTERNAL PIPEWORK

Ideally, external pipework, or pipework in unheated areas, should be avoided. If unavoidable, external pipework should be kept as short as possible (less than 3 metres) and 32 mm waste pipe used to minimise the risk of ice blocking the pipe in freezing conditions.

The number of bends, fittings and joints on external pipes should be kept to a minimum to reduce the risk of trapping condensate.

! NOTE !

For boilers installed in an unheated area such as a loft, basement, outhouse or garage, all condensate pipework should be as 'external'.

The pipework should be insulated using suitable waterproof and weather resistant insulation.

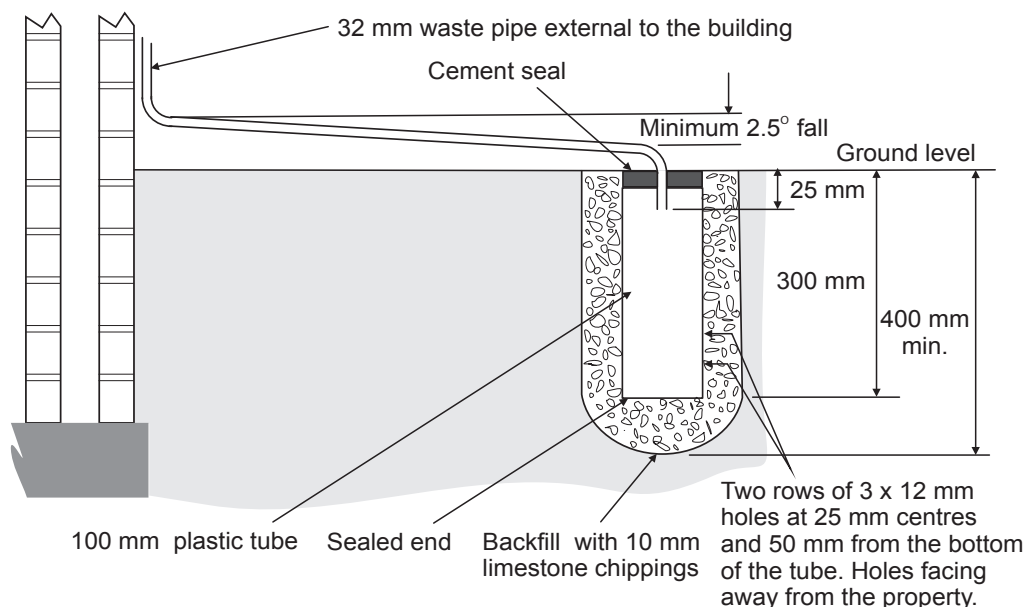

Figure 6-1: Purpose made condensate soakaway

6.5 CONDENSATE SOAKAWAY

To keep external pipework to a minimum, locate the soakaway as close as possible to the boiler but ensure it is at least 500 mm from building foundations and away from other services, e.g. gas, electricity, etc.

The condensate pipe may be run above or below ground level and can enter either the top or side of the soakaway tube. Refer to Figure 6-1.

Ensure that the drainage holes in the soakaway tube face away from the building.

Backfill both the soakaway tube, and the hole around it, with 10 mm limestone chippings.

Only use a soakaway where the soil is porous and drains easily. Do not use in clay soils or where the soil is poorly drained.

! CAUTION !

Any damage due to condensate backing up into the boiler due to a high water table, in the case of a soakaway, or flooded drains when the condensate disposal is via a gully or soil stack, is not covered by the Grant product guarantee.

6.6 CONDENSATE TRAP

Grant Vortex Eco External boilers are supplied with a condensate trap to provide the required 75 mm water seal in the condensate discharge pipe from the boiler.

The condensate trap is factory fitted inside the boiler casing - mounted on the inside of the left hand side panel at the rear of the boiler - in an accessible position to allow for routine maintenance, see Figure 6-2.

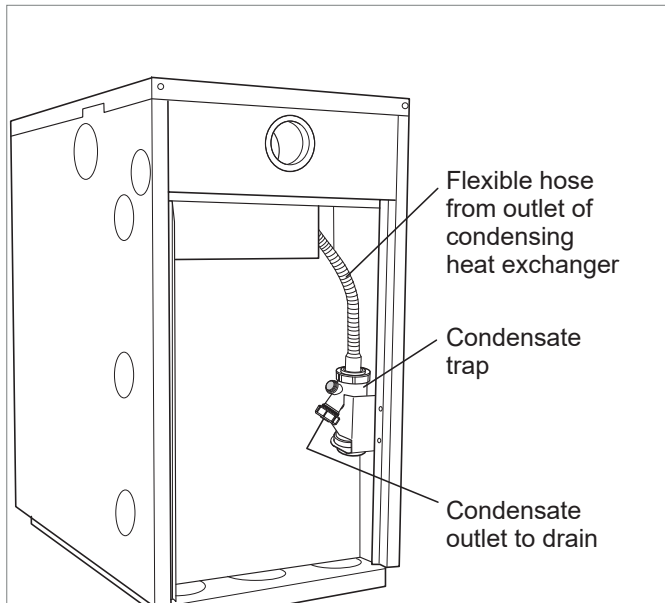

Figure 6-2: Condensate trap location

This trap incorporates a float (which will create a seal when the trap is empty) and an overflow warning outlet (fitted with a plastic sealing cap), see Figure 6-3.

! NOTE !

Access must be available to allow for routine maintenance.

A flexible hose connects the outlet of the condensing heat exchanger to the trap inlet. Ensure the elbow connector on the hose is fully pushed onto the 'top hat' inlet connector of the trap.

With the trap fitted inside the boiler casing, the sealing cap must be fitted. If the trap is re-located outside the boiler, then the following applies:

- If connecting the condensate discharge - either internally or externally - into a waste system or soil stack - the sealing cap must be fitted in the trap outlet.
- On external discharge systems to a hopper, gully or soakaway, the sealing cap should be removed from the trap outlet.
- If there is any discharge of condensate from the overflow outlet, this could indicate a blockage (possibly due to freezing). Turn off the boiler and investigate the cause. If necessary contact your service engineer for assistance.

! WARNING !

Care should be taken when siting the trap such that the overflow outlet is readily visible and that any condensate overflowing from the outlet cannot cause either a hazard to persons or damage to surrounding property or equipment.

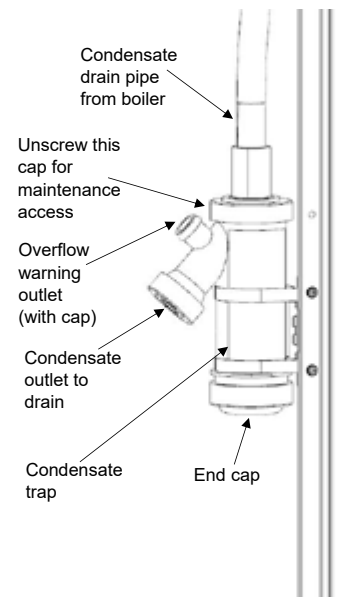

Figure 6-3: Condensate trap details

6.7 CONDENSATE DISPOSAL PIPEWORK

The condensate trap outlet is at an angle of 48° below the horizontal. This is to automatically give a 3° fall on any 'horizontal' runs of condensate disposal pipe. Refer to Figure 6-3 and see trap outlet/pipe.

The outlet of the trap will accept 21.5 mm to 23 mm OD Polypropylene overflow pipe for the condensate discharge pipe.

Possible routes for disposal pipework:

The boiler enclosure has several 50mm diameter openings in both the sides and 76mm diameter openings in the base. These are designed to allow pipework to pass through, to suit the installation. These openings can be used to allow the condensate disposal pipe to exit the casing in one of the following ways:

Side outlet - The lower opening on either side of the enclosure can allow the condensate disposal pipe to be installed as follows:

- Connection to an internal stack - passing back through the wall of the house.
- Connection to an external soil stack adjacent to the boiler.
- Discharge into an adjacent (external) drain or gully.
- Discharge into a soakaway - with the pipe either above or below ground level.

Bottom Outlet - There are three openings in the base that can allow the condensate disposal pipework to be installed as follows:

- Discharge into a drain or gully beneath the boiler (e.g. a drain built into the concrete base for the boiler).
- Discharge into a soakaway - with pipe below ground level.

! NOTE !

When connecting plastic discharge pipe, ensure that the pipe is fully pushed into the outlet end on the flexible hose to prevent the possibility of leakage.

6.8 INSPECTION AND CLEANING OF TRAP

The trap **must** be checked at regular intervals (e.g. on every annual service) and cleaned as necessary to ensure that it is clear and able to operate.

The bottom bowl can be unscrewed from the trap body for inspection and cleaning.

To inspect and clean the trap:

1. Disconnect flexible condensate hose from inlet connector.
2. Unscrew the inlet connection nut.
3. Remove the inlet connector and nut from trap.
4. Disconnect the condensate disposal pipe from the trap outlet.
5. Remove trap from bracket.
6. Remove float from trap – clean if necessary.
7. Inspect inside of trap and clean as necessary.
8. Check the condition of the flexible condensate hose between the trap and the boiler.
9. Re-assemble trap, re-fit to boiler and re-connect flexible hose. Ensure that hose is fully pushed onto the trap inlet connector.

! CAUTION !

Failure to regularly check and clean the condensate trap may result in damage to the boiler and will not be covered by the product guarantee.

7 SEALED SYSTEMS

7.1 SEALED SYSTEM REQUIREMENTS

All Grant Vortex Eco models are suitable for use with sealed systems complying with the requirements of BS EN 12828, BS EN 12831 and BS EN 14336.

The system must be provided with the following items:

- Diaphragm expansion vessel complying with BS EN 13831
- Pressure gauge
- Pressure relief (safety) valve
- Approved method for filling the system

7.1.1 EXPANSION VESSEL

The expansion vessel should be fitted in the return pipework as shown in Figures 7-1 and 7-2. To reduce the operating temperature of the expansion vessel, position it below the pipe to which it is connected.

The expansion vessel may be positioned away from the system, providing the connecting pipe is not less than 13 mm in diameter. If the expansion vessel is connected via a flexible hose, care must be taken to ensure that the hose is not twisted or kinked.

! NOTE !

Ensure that the expansion vessel used is of sufficient size for the system volume.

Refer to BS 7074-1 or The Domestic Heating Design Guide for sizing the required vessel.

7.1.2 PRESSURE GAUGE

The pressure gauge must have an operating range of 0 to 4 bar. It must be located in an accessible place next to the filling loop for the system.

7.1.3 PRESSURE RELIEF (SAFETY) VALVE

The pressure relief (safety) valve should be fitted in the flow pipework near to the boiler.

The pipework between the pressure relief (safety) valve and boiler must be unrestricted, i.e. no valves. The pressure relief (safety) valve should be connected to a discharge pipe which will allow the discharge to be seen, but cannot cause injury to persons or damage to property. Refer to Figure 7-3 for the position of the PRV on the sealed system models.

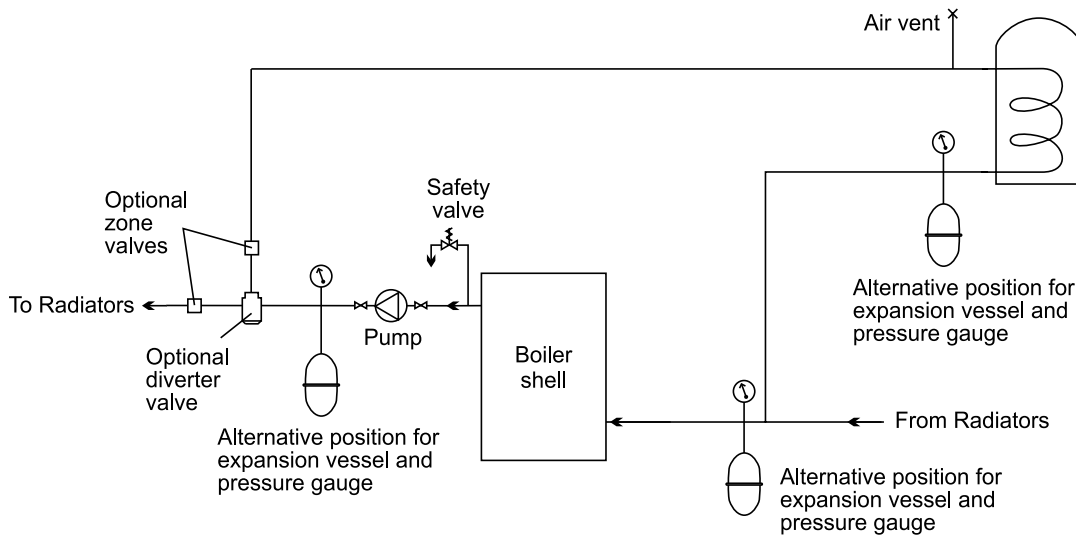

Figure 7-1: Sealed system

If thermostatic radiator valves are fitted, the system **must** incorporate an adequate by-pass.

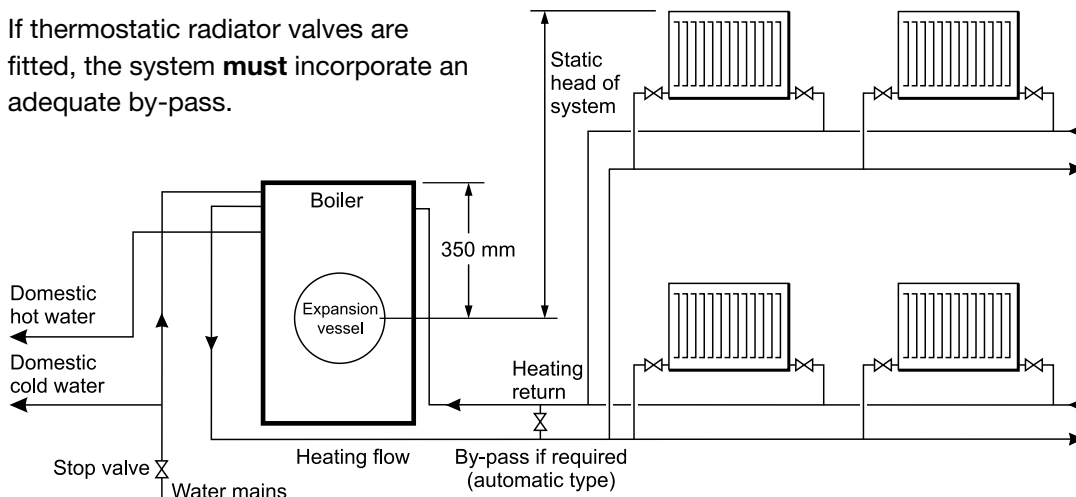

Figure 7-2: Sealed system boilers

7.1.4 FILLING LOOP

Provision should be made to replace water lost from the system. This can be done manually (where allowed by the local water undertaking) using an approved filling loop arrangement incorporating a double check valve assembly.

The filling loop must be isolated and disconnected after filling the system.

7.1.5 HEATING SYSTEM

The maximum 'setpoint' temperature for the central heating water is 75°C. Refer to Section 1.1.

An air vent should be fitted in the flow and return pipes of the highest point of the system.

If thermostatic radiator valves are fitted to all radiators, a system by-pass must be fitted. The by-pass must be an automatic type.

All fittings used in the system must be able to withstand pressures up to 3 bar. Radiator valves must comply with the requirements of BS 2767.

One or more drain taps (to BS 2879) must be used to allow the system to be completely drained.

7.2 FILLING THE SEALED SYSTEM

Filling of the system must be carried out in a manner approved by the local Water Undertaking.

! WARNING !

Only ever fill or add water to the system when it is cold and the boiler is off. Do not overfill.

The procedure for filling the sealed system is as follows:

1. Check the air charge pressure in the expansion vessel **BEFORE** filling the system.
The expansion vessel charge pressure should always be slightly greater than the maximum static head of the system, in bar, at the level of the vessel (1 bar = 10.2 metres of water). Refer to Figure 7-2.
The charge pressure must not be less than the actual static head at the point of connection.

! NOTE !

The air charge pressure may be checked using a tyre pressure gauge on the expansion vessel Schraeder valve. The vessel may be re-pressurised, when necessary, using a suitable pump. When checking the air pressure, the water in the heating system must be cold and the system pressure reduced to zero.

2. Check that the small cap (or screw) on all air vents is open at least one turn. The cap (or screw) remains in this position from now on.

3. Ensure that the flexible filling loop is connected and that the double check shut off valve connecting it to the water supply is closed. A valve is open when the operating lever is in line with the valve, and closed when it is at right angles to it.
4. Open the fill point valve.
5. Gradually open the double check valve from the water supply until water is heard to flow.
6. When the needle of the pressure gauge is between 0.5 and 1.0 bar, close the valve.
7. Vent each radiator in turn, starting with the lowest one in the system, to remove air.
8. Continue to fill the system until the pressure gauge indicates between 0.5 and 1.0 bar. Close the fill point valve. The system fill pressure (cold) should be 0.2 - 0.3 bar greater than the vessel charge pressure – giving typical system fill pressures of approx 0.5 bar for a bungalow and 1.0 bar for a two storey house.
Refer to the Domestic Heating Design Guide for further information if required.
9. Repeat steps 5 to 7 as required until system is full of water at the correct pressure and vented.
10. Water may be released from the system by manually operating the safety valve until the system design pressure is obtained.
11. Close the fill point and double check valves either side of the filling loop and disconnect the loop.
12. Check the system for water soundness, rectifying where necessary.

7.3 VENTING THE PUMP

For those heating circulating pumps fitted with a vent plug, it is important that the pump is properly vented to avoid an air lock and also prevent it running dry and damaging the bearings.

Unscrew and remove the plug from the centre of the pump motor. Using a suitable screwdriver, rotate the pump spindle about one turn. Replace the plug in the motor. Do not over tighten.

! NOTE !

Some heating circulating pumps are not fitted with a vent plug so it is not possible to vent these pumps in the manner described above. Refer to pump manufacturers own instructions for further details.

If a Wilo Para pump is used, please refer to Appendix A2 at the back of this installation and servicing manual for guidance on venting the pump.

7.4 PRESSURE RELIEF (SAFETY) VALVE OPERATION

Check the operation of the pressure relief (safety) valve as follows:

1. Turning the head of the valve anticlockwise until it clicks. The click is the safety valve head lifting off its seat allowing water to escape from the system.
2. Check that the water is escaping from the system.
3. Top-up the system pressure, as necessary, by following the procedure outlined in Section 7.2.

7.5 SYSTEM MODELS

All System models have the following sealed system components factory fitted (refer to Figure 7-3):

- A diaphragm expansion vessel complying with BS 4814, pre-charged at 1.0 bar. Refer to Section 2.2.
- System pressure gauge, with an operating range of 1 to 4 bar.
- Pressure relief safety valve complying with BS 6759 and set to operate at 3.0 bar.
- Air vent, fitted to the flow pipe of the boiler, ensures the boiler is vented.
- Filling loop. This must be isolated and disconnected after filling the system.

Refer to Section 2.2 for system volumes and BS 7074: for further guidance and for further details of the expansion vessel.

For information on the circulating pump fitted to sealed system models, please refer to Appendix A1 or A2 as required at the back of this installation and servicing manual.

The expansion vessel fitted, is supplied with a charge pressure of 1.0 bar (equivalent to a maximum static head of 10.2 metres). The charge pressure must not be less than the actual static head at the point of connection.

! CAUTION !

Do not pressurise the vessel above 1.5 bar.

! NOTE !

The air pressure in the vessel must be checked annually.

The central heating system volume, using the expansion vessel as supplied, must not exceed the recommended value. Refer to Section 2.2. If the system volume is greater, an extra expansion vessel (complying with BS 4841) must be fitted as close as possible to the central heating return connection on the boiler. The charge pressure of the extra vessel must be the same as the vessel fitted in the boiler.

Refer to either BS 7074:1:1989 or The Domestic Heating Design Guide for the required total expansion vessel volume for the system concerned.

! NOTE !

The air charge pressure may be checked using a tyre pressure gauge on the expansion vessel Schraeder valve. The vessel may be re-pressurised using a suitable pump. When checking the air pressure the water in the heating system must be cold and the system pressure reduced to zero.

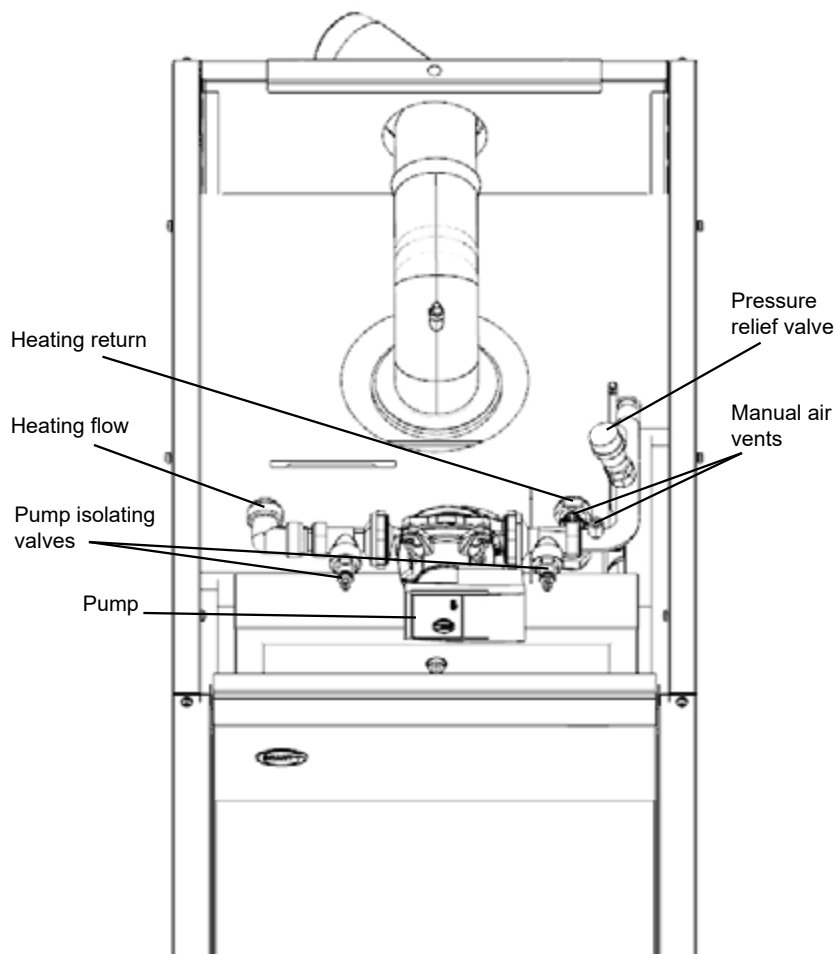

Figure 7-3: Sealed system components

8 ELECTRICAL

! WARNING !

Ensure that the electrical supply has been isolated before making any connections to the boiler.

8.1 GENERAL

Grant Vortex Eco External models require a ~230V 1ph 50Hz supply. It must be protected by a 5 Amp fuse.

Refer to Figures 8-1 and 8-2 for typical control system wiring diagrams for all models.

Refer to Figure 8-3 for control panel wiring diagrams for all Vortex Eco External models.

! WARNING !

The Vortex boiler contains electrical switching equipment and must be earthed.

The supply must be fused at 5 Amp and there must only be one common isolator for the boiler and control system, providing complete electrical isolation.

A fused double pole switch or a fused three pin plug and shuttered outlet socket should be used for the connection.

The power supply cable should be at least 0.75 mm² PVC as specified in BS 6500, Table 16.

All the wiring and supplementary earth bonding external to the boiler must be in accordance with the current IET Wiring Regulations.

Any room thermostat or frost thermostat used must be suitable for use on mains voltage.

In the event of an electrical fault after installation of the boiler, the following electrical system checks must be carried out:

- Short circuit
- Polarity
- Earth continuity
- Resistance to earth

! NOTE !

If the supply cord is damaged, it must be replaced by the manufacturer, its service agent or similarly qualified persons in order to avoid a hazard.

8.2 CONNECTING THE POWER SUPPLY

It is recommended that the boiler should be connected to a switched mains power supply from a programmer or control system.

A three core cable is required to connect the boiler terminal block to the live supply.

Refer to Figures 8-1 and 8-2 for typical control system wiring diagrams.

! NOTE !

Ensure that the route and length of the supply cable is such that the boiler front cover plate can be easily removed without disconnecting the supply cable from the terminal block.

The procedure is as follows:

1. Remove the casing door on the front of the external module, then remove the four screws retaining the top casing panel and remove the top casing panel.

2. Remove the three screws securing the left hand cover to the control panel and remove this cover to gain access to the boiler terminal block.
3. Loosen/remove the screws securing the cable clamp and open the clamp.
4. Route the supply and pump cables into the enclosure as outlined in Section 4.8.
5. Pass the mains power supply cable through the cable grommet in the back of the control panel, through the cable clamp and connect to the boiler control panel terminals as follows:
 - Brown to mains live (terminal 2)
 - Blue to mains neutral (terminal 3)
 - Green/Yellow to mains earth (terminal 4)
6. If the circulating pump is to be fitted inside the boiler enclosure, pass the 3-core cable from the pump through the cable grommet and through the clamp and connect to the boiler control panels as follows:
 - Green/Yellow to pump earth (terminal 10)
 - Blue to pump neutral (terminal 9)
 - Brown to pump live (terminal 7)

! NOTE !

Connecting the pump in this manner allows the pump to be isolated using the isolated switch inside the boiler control panel, for servicing and maintenance work.

7. Make the remaining required connections to the control panel, as detailed in Figures 8-1 and 8-2.
8. Tighten the cable clamp and refit the front of the control panel and terminal block cover, taking care not to trap any wires.

! WARNING !

After completing electrical connections and before reconnecting the electrical supply to the boiler, replace the terminal block cover and secure it using the screws provided.

9. Re-connect the electrical supply and check operation of heating system controls (programmer, room thermostats, etc.).
10. Refer to Instructions provided with the programmer for operation and setting.
11. Leave the Programmer and Thermostat Instructions with the user after installation for their future reference.

BURNER LEAD PLUG/SOCKET CONNECTOR

On all models, the electrical cable between the boiler control panel and burner is now fitted with an in-line 3-way plug and socket connector. This enables the burner to be easily disconnected from the boiler control panel for ease of removal and servicing.

! NOTE !

A Service switch is fitted to the control panel to allow the Service Engineer to test-fire the boiler.

When set to 'ON' the switch temporarily by-passes the external control system to operate the boiler.

This is a 'momentary' or non-latching switch that cannot be left set to ON. The boiler will automatically revert to normal operation when 15 minutes have elapsed since it was last operated. If required, this 15 minute override period can be stopped by switching the boiler On / Off switch OFF and then back to ON.

The boiler will then operate as normal under control of the external heating/hot water controls (timer, room thermostat or programmer).

8.3 FROST PROTECTION

The boiler is fitted with a pre-set internal frost protection thermostat. If the air temperature around the boiler falls below 2°C, then this thermostat will be activated to protect the boiler from freezing.

Also, to protect any exposed heating system pipework, it is recommended that an 'external' frost thermostat is also installed. This frost thermostat will operate in parallel with the internal frost protection of the boiler.

It should be sited within the house in such a place that it can detect any rise and fall in the ambient air temperature, i.e. in a room with a radiator.

Where the frost thermostat is installed outside the house (to protect a boiler installed in an external boiler room or garage) or in an attic, it is recommended that it be used in conjunction with a pipe thermostat to avoid unnecessary and wasteful overheating of the property. The pipe thermostat should be located on the boiler return pipe, and set to operate at 25°C.

For connection details please refer to Figures 8-1 and 8-2.

! NOTE !

For total system protection against freezing, particularly during extended periods without electrical power, Grant recommend the use of a combined heating system antifreeze and corrosion inhibitor, used in accordance with the manufacturer's instructions.

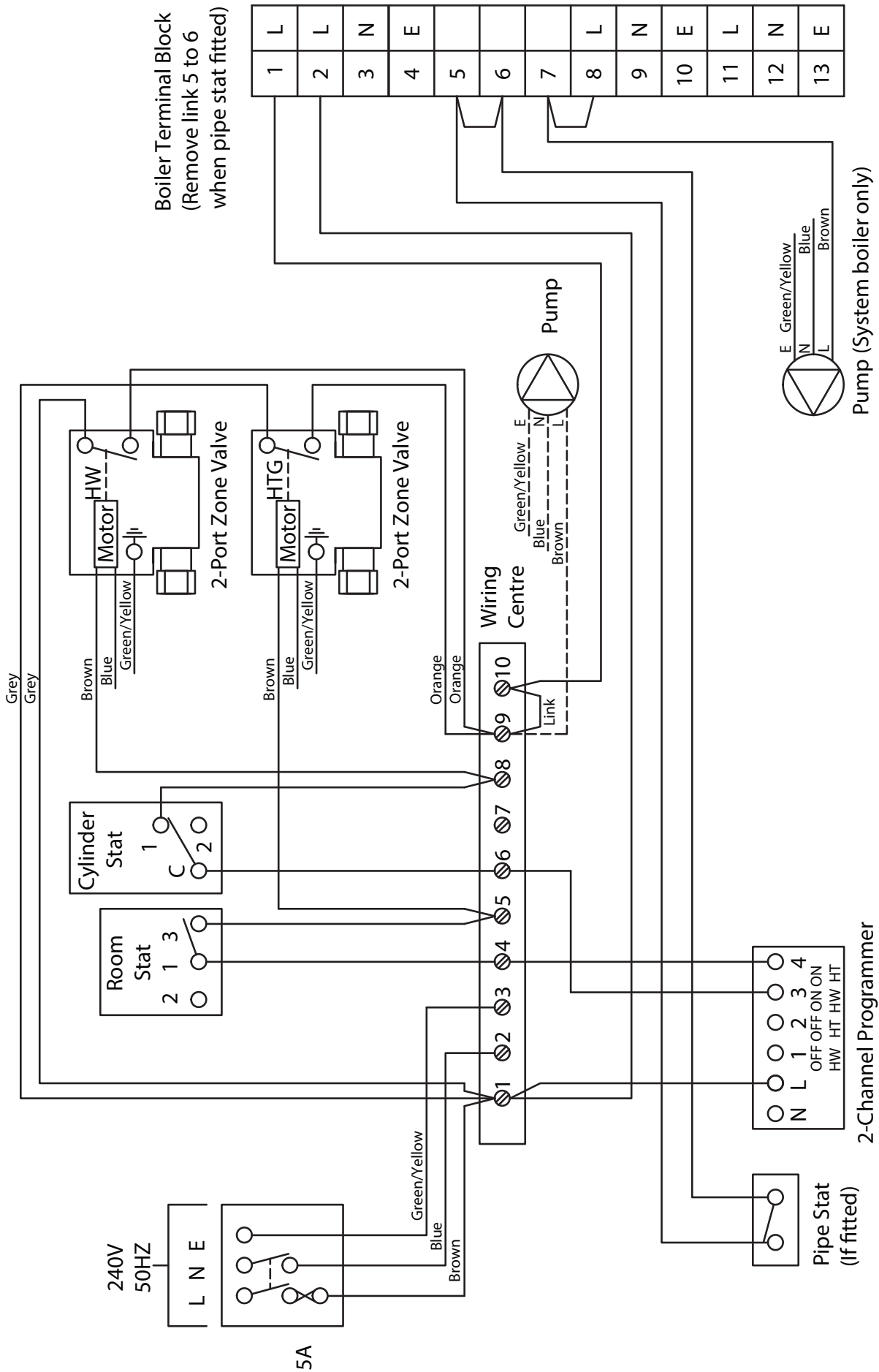

Figure 8-1: Vortex Eco External Module with S-plan type control system wiring diagram

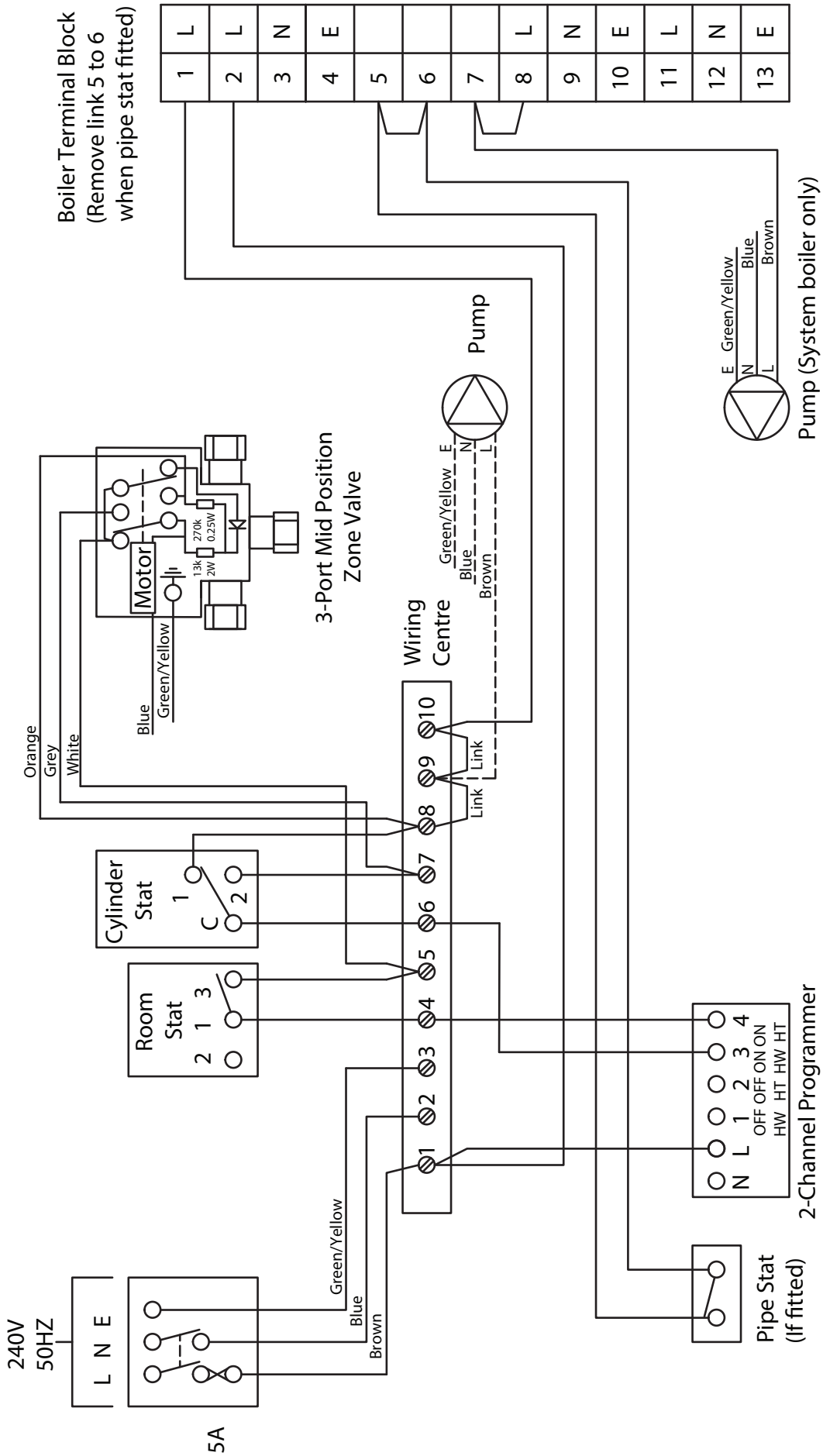

Figure 8-2: Vortex Eco External Module with Y-plan type control system wiring diagram

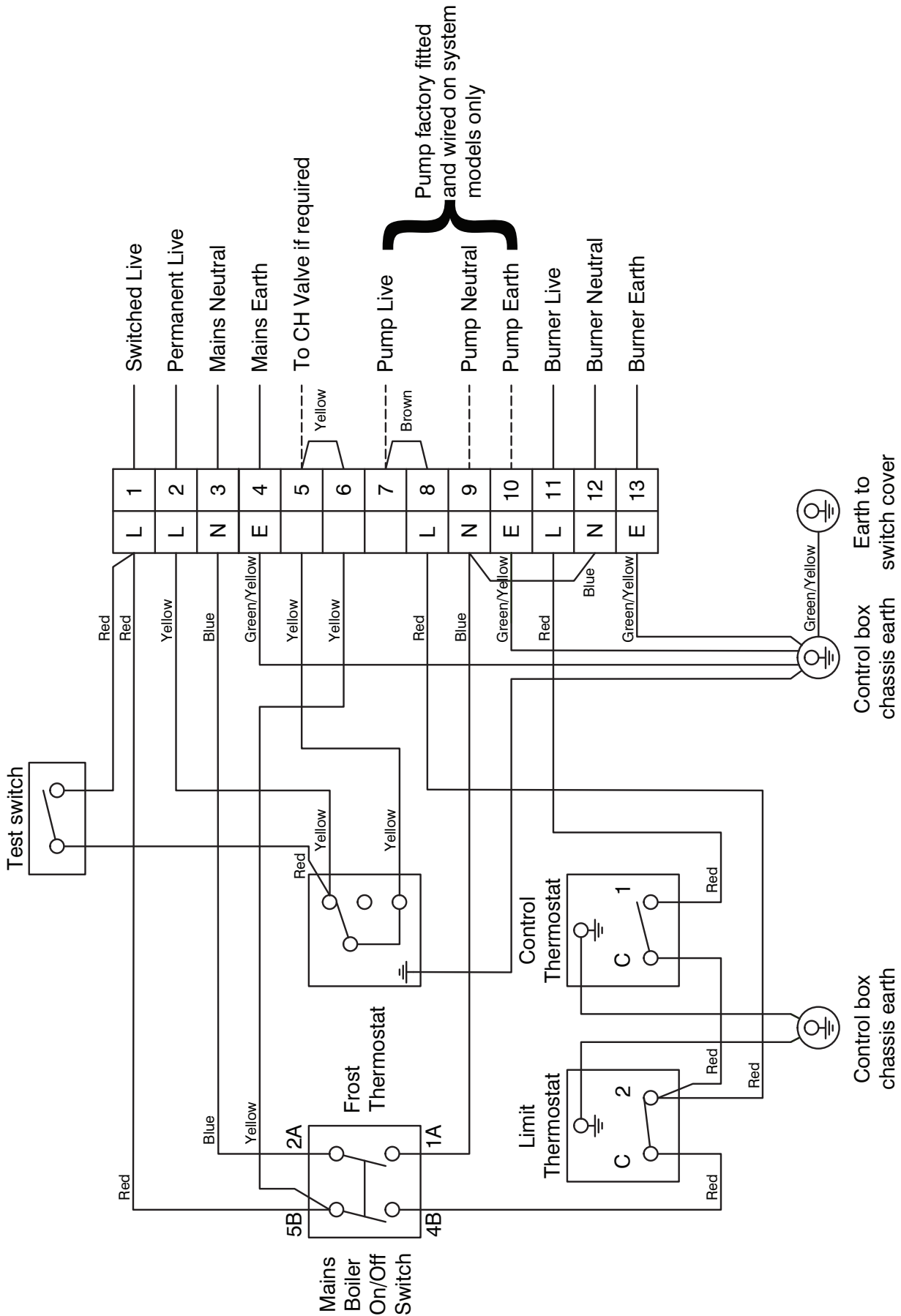

Figure 8-3: Vortex Eco External Module control panel wiring diagram

9 FLUE SYSTEM AND AIR SUPPLY

The boiler is supplied with a flue terminal. Refer to Section 4.7 for fitting details.

As an alternative to the terminal supplied, there are three external flue systems that can be used with the Vortex Eco External boiler, all available from Grant UK.

PLUME DIVERTER KIT

This vertical system is available to purchase from Grant UK and is intended to be retrofitted to the flue terminal supplied with the boiler, in order to terminate the flue in a more preferable or permissible location.

GRANT GREEN SYSTEM

VERTICAL:

This vertical twin wall stainless steel insulated system replaces the low level terminal supplied with the boiler, and may terminate at high level or vertically as required.

HORIZONTAL:

This option allows the extension of the flue system in the horizontal plane in order to terminate the flue in a more preferable or permissible location.

These systems are described in this section.

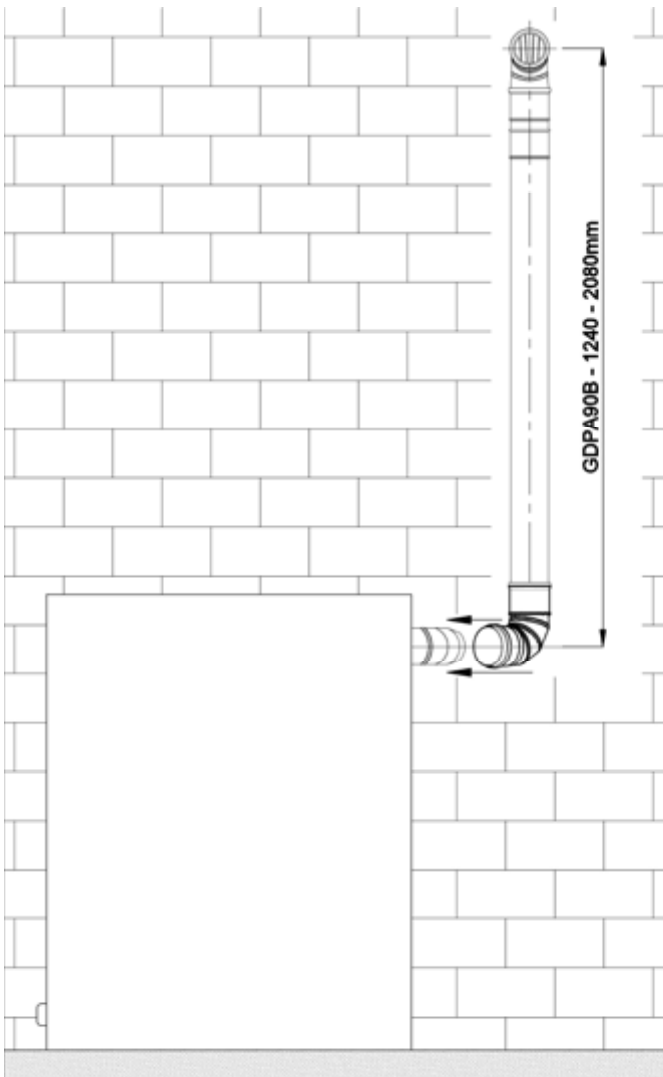

Figure 9-1: Plume diverter kit - Front View

! NOTE !

Ensure that the Plume Diverter Kit starter elbow is fully pushed onto the external boiler flue terminal. See above.

9.1 AIR SUPPLY

A sufficient permanent air supply to the boiler should be provided for the following reasons:

- For proper combustion of fuel and effective discharge of combustion products to the open air.
- For the ventilation of any confined space in which the boiler is installed to prevent overheating of the boiler and any equipment in and near the boiler.

Grant external boilers draw their air supply via the ventilation holes in recessed top edge of the front door of the boiler casing. These ventilation holes must not be obstructed.

Further details may be obtained from BS 5410-1.

9.2 PLUME DIVERTER KIT

Should the low level flue supplied with the boiler be discovered to cause a plume nuisance after its installation, a plume diverter kit is available to purchase from Grant UK for the purpose of re-directing the flue gases to a higher level (according to the minimum clearances shown in Figure 9-5).

The plume diverter kit has been designed to be retrofitted to the low level flue supplied with the external boiler by attaching the 90° elbow supplied with the kit directly to the boiler flue terminal.

This kit is available in two sizes, only one of which is to be used with the Eco External boilers, product code as follows:

- GDPA90B - (maximum vertical length of 2.08m)

While every effort has been made to make this retrofit as simple as possible for the installer, it is necessary for the installer to drill an 8mm hole in the side of the existing flue terminal to ensure that the condensate produced by the flue gases during normal operation drain back into the boiler.

It is also necessary for the installer to spot drill two 3mm holes in the existing flue terminal. With the plume diverter starter elbow in its final position on the existing flue terminal, use the holes in either side of this elbow as a guide to drill the two holes in the terminal and fix the elbow to the existing terminal by driving one of the two self-tapping screws provided into each hole.

More detailed installation details for this system can be found in the fitting instructions supplied with the kit.

Please see Figures 9-1 and 9-2 for a visual representation of the plume diverter kit fitted onto a Grant Vortex Eco External boiler.

A series of extensions and other accessories are available for use with this kit. Please contact Grant UK for further information.

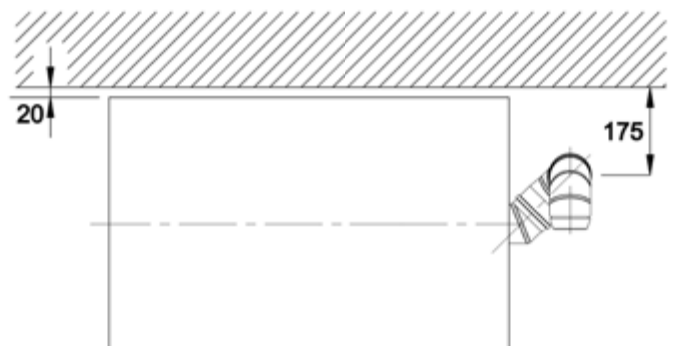

Figure 9-2: Plume diverter kit - Plan View

9.3 CONVENTIONAL FLUE SYSTEMS

! NOTE !

Under no circumstances can Grant Vortex boilers be installed with existing flue systems. Only flue systems and components suitable for wet flues should be used.

Failure to install the correct type of flue system will invalidate the guarantee.

Grant condensing boilers have high operating efficiencies and low flue gas temperatures. Care must be taken to ensure the flue system is suitable for the very low flue gas temperatures and condensate in the flue gases.

Suitable conventional flue systems are available from Grant UK.

The flue must terminate in a down draught free area, i.e. at least 600 mm above the point of exit through the roof or preferably above the ridge level.

The condensate may be allowed to run back into the boiler. A condensate drain at the base of the flue system is not required.

The high level flue terminal must be at least 600 mm from any opening into the building, and 600 mm above any vertical structure or wall less than a horizontal distance of 750 mm from the terminal.

More detailed information on the siting of the flue terminal can be found in Figure 9-5 and Table 9-2.

The internal flue diameter for all models must be 100 mm (4 in).

Twin wall flues are recommended for externally run flues to reduce the possibility of the condensate freezing in the flue.

No part of any flue system should be made of an asbestos material; aluminium must not be used in any part of the flue. Only stainless steel flue components should be used.

If the draught conditions are satisfactory, the flue should terminate with a standard cowl.

Refer to the locally applicable Building Regulations, BS 5410-1 and OFTEC Installation Requirements (OFTEC Books 2 and 3) for further guidance on conventional flue systems.

! CAUTION !

It is important to ensure that the flue system is sealed and that condensate cannot escape. Up to 1.5 l/h of condensate can be produced in a conventional flue system.

Do not use fire cement. The use of high temperature silicone sealants is recommended.

! NOTE !

To comply with the requirements of the Building Regulations Approved Document J - conventional flue systems must have a flue data plate.

9.4 EXTERNAL VERTICAL CONVENTIONAL FLUE (GREEN SYSTEM)

The external system can terminate at either high level or vertically (above roof level) as required. The vertical or high level terminal must terminate in accordance with BS 5410-1. The minimum dimensions for locating the high level terminal from building features (windows, doors, etc.) are shown in Figure 9-5.

The Green system comprises of five insulated extension lengths, 45° elbows, a vertical terminal and a high level horizontal terminal.

Locking bands are provided with all vertical extensions and terminals. Ensure that the locking bands are fitted.

Two types of wall bracket are also available (standard and adjustable) to support the vertical flue components.

The maximum vertical height (from the top of the boiler to the terminal) for the 100mm diameter 'Green' system twin wall flue is 19 metres. Only two 45° elbows may be used in the complete system.

If the flue terminal is fitted less than 2 metres above a surface to which people have access, the terminal must be protected by a guard. The guard must be manufactured from stainless steel and should be fitted centrally over the flue terminal and securely fixed to the wall.

CONNECTION OF GREEN FLUE SYSTEM

1. Connect Grant Green system (100mm twin wall flue) to the boiler flue outlet using the Grant Green system External Module starter elbow (product code: GKM90).
2. Fit the starter elbow into the boiler connector after first ensuring that the seal is in place in the connector.

! NOTE !

Lubricate the seal on the boiler connector using the lubricant provided before attempting to fit the starter piece.

Ensure that seals in all flue sections are lubricated before installing.

3. Assemble the remainder of the flue system as required, lubricating the seal on each component before fitting and securing every joint with the locking band provided.

The external vertical flue (Green system) components available from Grant UK can be found in Figure 9-3 and Table 9-1.

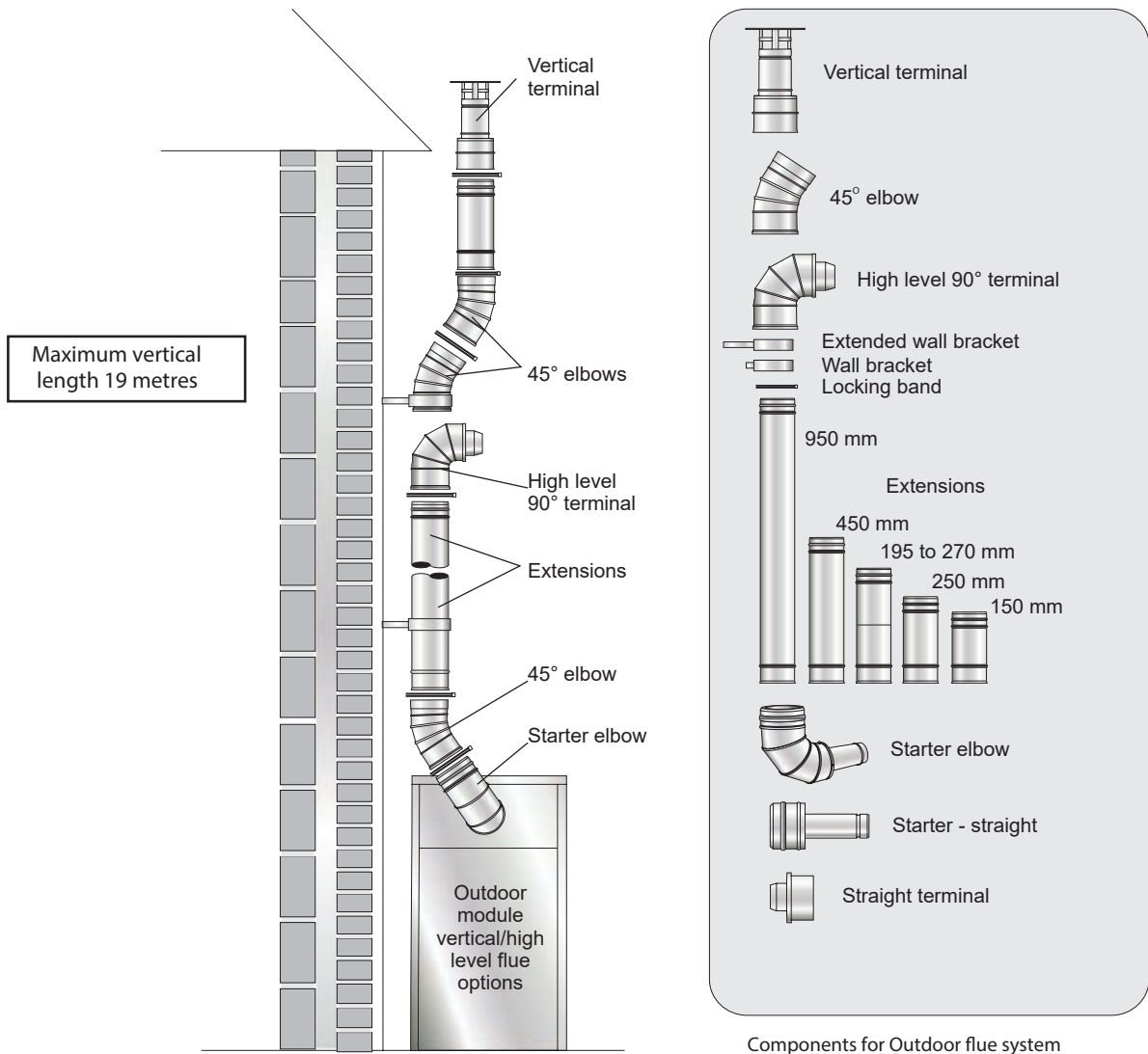

Figure 9-3: Vertical external conventional flue (Green system)

Green System Components	
Item - for all Eco External models	Part No.
External starter elbow	GKM90
External starter - straight	GKM90C
150mm extension	GX150/90
250mm extension	GX250/90
450mm extension	GX450/90
950mm extension	GX950/90
195-270mm adjustable extension	GXA250/90
45 elbow	GE45/90
High level terminal	GTH90
Vertical terminal	GTV90
Wall bracket - standard	GWB90
Wall bracket - extended	GEB90
Straight terminal - horizontal flue	GTL90

Table 9-1: Green system components - product codes

9.5 EXTERNAL HORIZONTAL CONVENTIONAL FLUE (GREEN SYSTEM)

This option uses the Grant Green system External Module straight starter section (GKM90C), replacing the low level terminal and flue guard supplied with the boiler, along with components from the Grant Green system. See Figure 9-4.

It is possible to extend the flue horizontally by a maximum of 3 metres in total flue length by using the green system. A maximum of two 45° elbows may be utilised when extending the flue using this system.

For further information on the connection of the Green system, please refer to Section 9.4.

! NOTE !

The flue system from the external module can be extended either vertically OR horizontally by using the Green System.

NOT a combination of both.

A complete list of Grant Green system flue components can be found in Figure 9-3 and Table 9-1.

Information on the siting of the flue terminal can be found in Section 9.6.

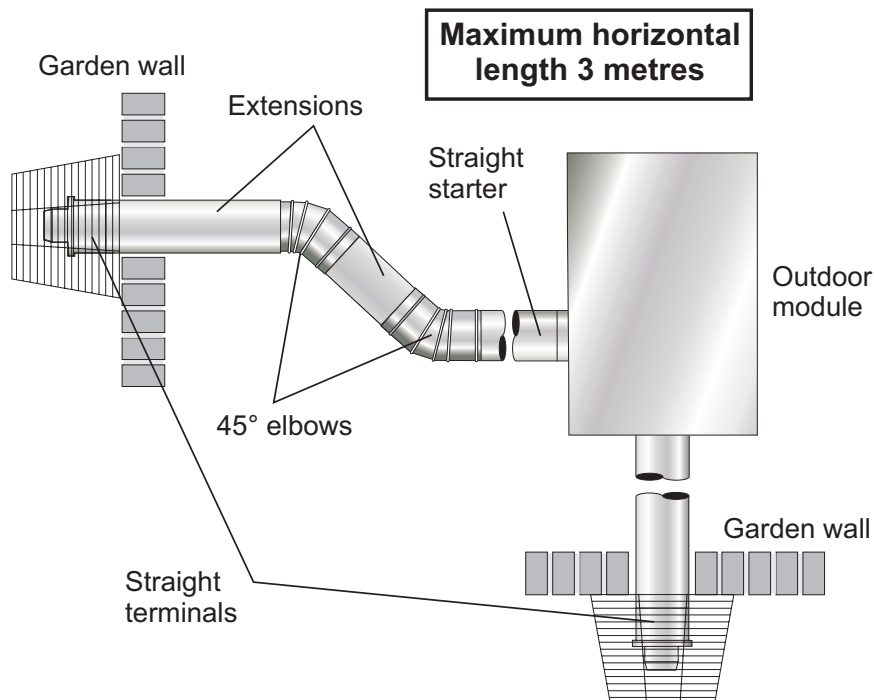

Figure 9-4: Horizontal external flue

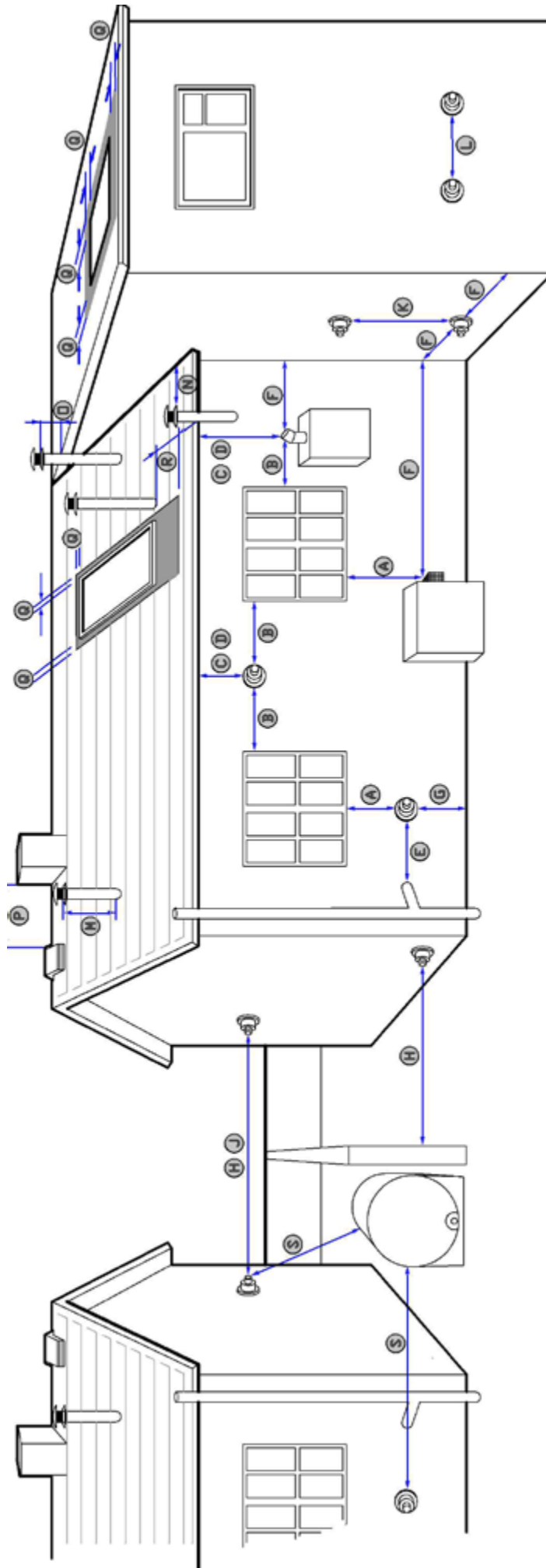

Figure 9-5: Flue clearances

Table 9-2: Flue clearances

Ref	Location of outlet	Minimum distance (mm)	
		Pressure jet	Condensing
A	Directly below an opening, air brick opening, opening window, etc.	600	1,000 **
B	Horizontally to an opening, air brick opening, opening window, etc.	600	1,000 **
C	Below a gutter, eaves or balcony with protection	75 *	1,000 **
D	Below a gutter, eaves or balcony without protection	600	1,000 **
E	From vertical sanitary pipework	300	
F	From an internal or external corner	300	
G	Above ground or balcony level	300	
H	From a surface or boundary facing the terminal	600	2,500 **
J	From a terminal facing the terminal	1,200	
K	Vertically from a terminal on the same wall	1,500	
L	Horizontally from a terminal on the same wall	750	
M	Above the highest point of an intersection with the roof	600	
N	From a vertical structure to the side of the terminal	750	
O	Above a vertical structure less than 750 mm from the side of the terminal	600	
P	From a ridge terminal to a vertical structure on the roof	1,500	
Q	Above or to the side of any opening on a flat or sloping roof	300	
R	Below any opening on a sloping roof	1,000	
S	From oil storage tank (Class 1)	1,800 ***	

* A heat shield at least 750 mm wide must be fitted to provide protection of combustible material.

** Clearances required by BS 5410-1:2019 to alleviate the effect of plume nuisance. If a risk assessment shows that there will be no impact from pluming, then the 'pressure jet' figure could apply - seek confirmation from Local Authority Building Control.

*** Seek guidance from OFTEC Book 3 (Oil Storage and Supply).

NOTES

- Appliances burning class D fuel have additional restrictions. Refer to BS 5410-1:2019.
- Vertical structure in N, O and P includes tank or lift rooms, parapets, dormers, etc.
- Terminating positions A to L are only permitted for appliances that have been approved for low level flue discharge when tested in accordance with BS EN 303-1, OFS A100 or OFS A101.
- Terminating positions should be at least 1.8 metres from an oil storage tank (Class 1) unless a wall with at least 30 minutes fire resistance and extending 300 mm higher and wider than the tank is provided between the tank and the terminating position.
- Where a flue is terminated less than 600 mm away from a projection above it and the projection consists of plastics or has a combustible or painted surface, then a heat shield of at least 750 mm wide should be fitted to protect these surfaces.
- If the lowest part of the terminal is less than 2 metres above the ground, balcony, flat roof or other place to which any person has access, the terminal should be protected by a guard.
- Notwithstanding the dimensions given above, a terminal should not be sited closer than 300 mm to combustible material. In the case of a thatched roof, double this separation distance should be provided. It is also advisable to treat the thatch with a fire retardant material and close wire in the immediate vicinity of the flue.
- A flue or chimney should not pass through the roof within the shaded area delineated by dimensions Q and R.
- Where protection is provided for plastics components, such as guttering, this should be to the standard specified by the manufacturer of the plastics components.
- Terminals must not be sited under car ports.
- Terminals at low levels (terminals under 2.1 metres) have more restrictive recommendations and should not be positioned near public footways, frequently used access routes, car parking spaces less than 2.5 metres from the terminal or patio's (hard surface area).

Further guidance can be obtained from BS 5410-1:2019, OFTEC Book 4 (Installation) and Approved Document J.

Grant UK flue products are fully compliant with the CE (Communauté Européenne/European Community) standards having undergone rigorous product testing.

10 COMMISSIONING

To ensure safe and efficient operation, it is essential that a Grant Vortex Eco boiler is commissioned as detailed in the following procedure.

To access the controls, remove the front door from the boiler casing (pull forward at the bottom and then lift off).

The controls are shown in Figure 10-1 and the boiler components are shown in Figure 10-2.

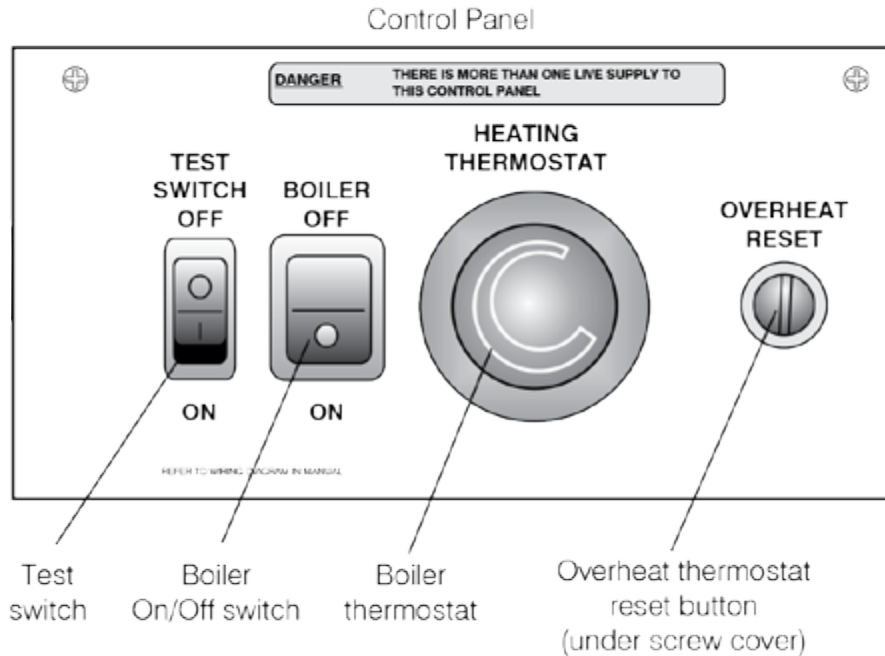

Figure 10-1: Vortex Eco boiler control panel

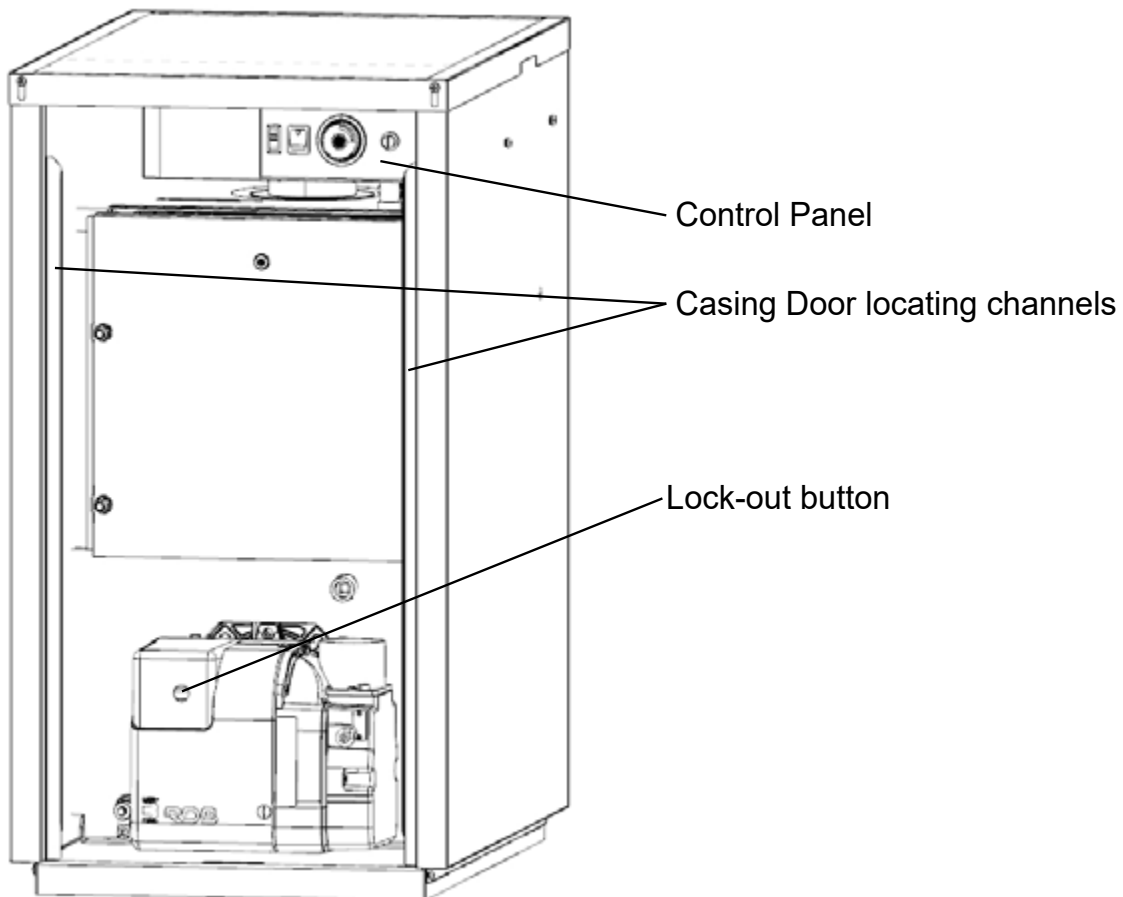

Figure 10-2: Position of boiler components - Vortex Eco External boiler

10.1 BEFORE SWITCHING ON

1. Ensure the boiler is isolated from the electrical supply and the boiler On/Off switch is set to OFF.
2. Remove the front casing door.
3. Remove the four screws retaining the top casing panel and remove the top casing panel, then check that the high limit thermostat bulb and boiler thermostat bulb are correctly located in their respective pockets. Refer to Figures 5-1 to 5-4. Check condition of both thermostat capillaries. Ensure they are not damaged, broken, kinked or crushed.
4. Remove the nuts and washers securing the front cleaning door. Withdraw the door – take care as it is heavy!
5. Check that the turbulators are in position and that the ends are vertical. Refer to Figure 11-3.
6. Check that the baffles are in position. Refer to Figures 11-1 and 11-2, as required.
7. Re-fit cleaning door and check it is fitted correctly and that a good seal is made.
8. Unscrew the burner fixing nut (located at the top of the mounting flange) and remove the burner from the boiler.
9. Check/adjust the burner settings as described in Section 10.2.
10. Re-fit the burner to the boiler and tighten the fixing nut. DO NOT OVERTIGHTEN!
11. Check that the sealed system has been vented and pressurised and there are no leaks.
12. Ensure that the condensing heat exchanger has been vented via the manual air vent (on heating return connection). Refer to Section 5.
13. Ensure that the air vent on the heating flow pipe (system version only) is open. Refer to Section 5.
14. Check that all fuel line valves are open.
15. Remove the plastic burner cover if it was not previously removed.
16. Connect a combined vent manifold and pressure gauge to the pressure gauge connection port on the oil pump. See Figure 3-5. Open the vent screw on the vent manifold to vent the oil supply whilst the pump is running.
17. Check that all system controls are calling for heat and turn the boiler thermostat to maximum.

10.2 BURNER SETTINGS: RDB2.2 BX BURNERS

With the burner removed from the boiler:

1. Unscrew and remove the two screws holding the air intake spigot to the top of the air inlet cover.
2. Remove and discard the air intake spigot and gasket.
3. Fit the slotted air intake (provided loose with the boiler) to the top of the air intake cover and secure using one of the two screws previously removed.
4. Remove the burner head. Refer to Figure 10-3. Loosen the three fixing screws (1) and remove head (2) from burner.

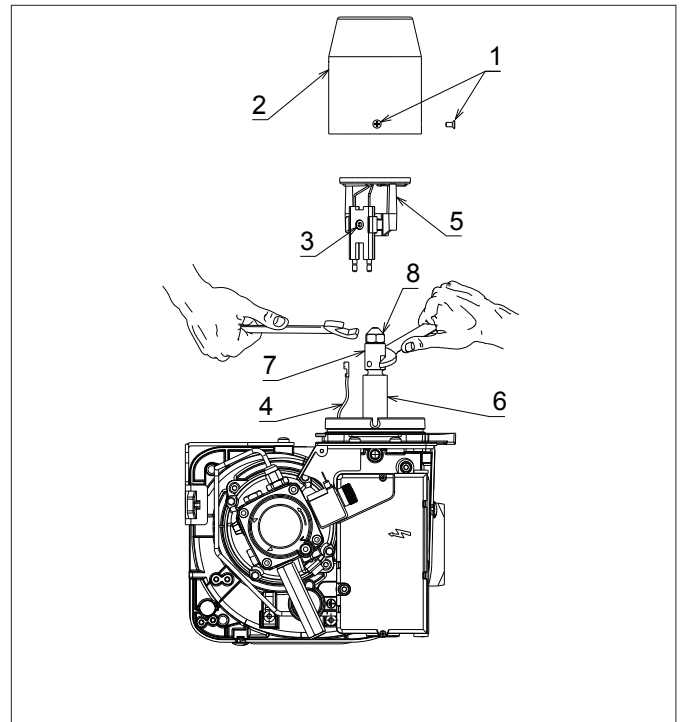

Figure 10-3: Burner head, recirculation tube (if fitted) diffuser and nozzle holder

5. Check the nozzle is correct for the required boiler output. Refer to Table 2-3 for the correct nozzle size and type for the required boiler output.
6. If the nozzle needs to be replaced - remove the diffuser/ electrode assembly. Refer to Figure 10-3.
 - Using a 4 mm Allen key, loosen the diffuser fixing screw (3) on the electrode assembly.
 - Lift diffuser/electrode assembly (5) up and off the nozzle holder.
 - Disconnect both ignition leads (4) from the electrodes.
7. Use a 16 mm spanner to remove/re-fit the nozzle (8), whilst holding the nozzle holder (6) using a 19 mm spanner.

! CAUTION !

The use of an ill-fitting spanner will damage the nozzle and could lead to an incorrect flame pattern and poor combustion.

! NOTE !

Ensure that the nozzle is securely tightened so that it does not leak but DO NOT OVER TIGHTEN!

8. Re-fit the diffuser/electrode assembly. Refer to Figure 10-3.
 - Reconnect ignition leads (4) to electrodes.
 - Re-fit the diffuser/electrode assembly (5) onto the nozzle holder lining up the fixing screw with the recess in the nozzle holder.
 - Ensure diffuser assembly is fitted down hard onto the shoulder on the nozzle holder.
 - Tighten the fixing screw (3) to secure the diffuser/ electrode assembly in place on the nozzle holder.

! NOTE !

Do not overtighten the fixing screw as this may damage the electrode insulator.

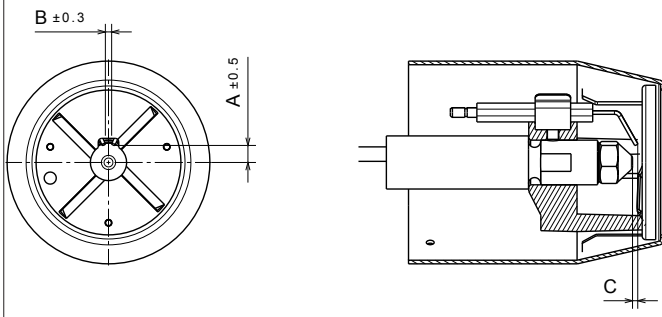

Figure 10-4: Ignition electrode settings

Model	A	B	C
External 15/21 & 21/26 External System 15/21 & 21/26	7	2.5	2.5 - 3
External 26/35 External System 26/35	4.5	3	2 - 2.5

6. Check/adjust electrode setting. Refer to Figure 10-4.
7. Re-fit the burner head. Refer to Figure 10-3.
 - Locate the head fixing screws (1) in the countersunk slots in the burner collar.
 - Check that the small oil drip hole (on the head) is pointing downwards.
 - Tighten the three screws (1) to secure the head (2) in position on the burner.
8. Adjust the diffuser position. Refer to Figure 10-5.

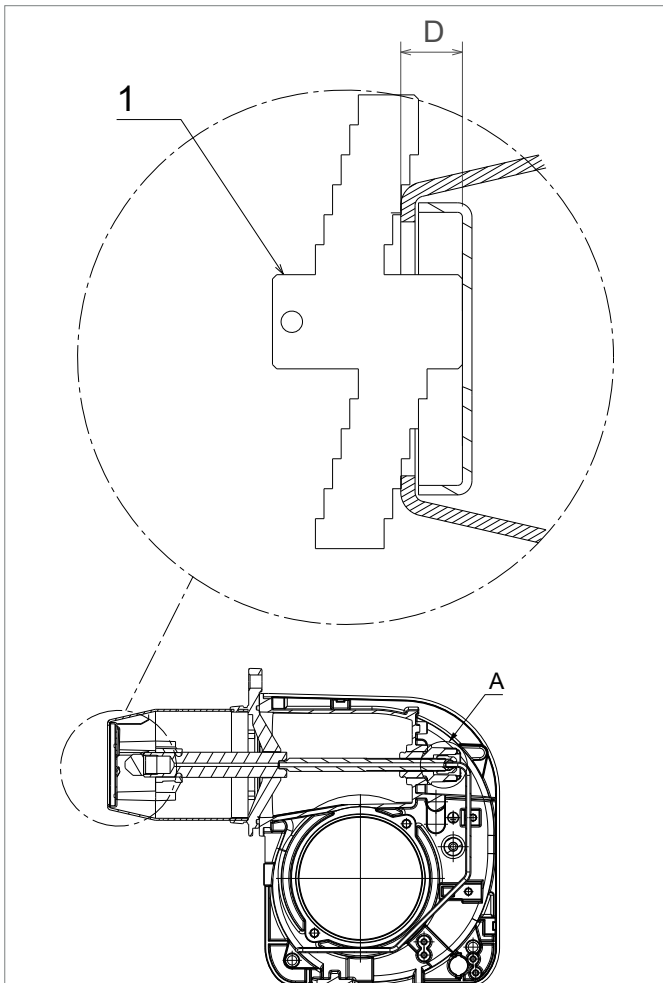

Figure 10-5: Riello RDB 2.2 BX diffuser position and gauge plate

! NOTE !

The distance between the end of the burner head and the front face of the diffuser (D) MUST be correctly set for the burner to operate correctly.

- Refer to Table 2-3 for the required distance (head setting) for the boiler output required.
- Check the distance D using the gauge plate supplied with the boiler.
- To use the gauge plate:
 - Position the gauge on the burner head as shown in Figure 10-5.
 - Locate the gauge with the correct steps (i.e. the two marked with the required distance D) resting on the edge of the burner head.
 - Check the gauge plate is at 90° to the end of the burner head and is positioned at the full diameter of the head.
 - If the distance D is correct, the tongue of the gauge should just make contact with the diffuser, with BOTH steps still in contact with the edge of the burner head.
 - If the steps are not in contact with the edge of the burner head, when the tongue of the gauge is touching the diffuser, the diffuser must be 'opened' (see below).
 - If the tongue does not reach the diffuser, when the steps are in contact with the edge of the burner head, the diffuser must be 'closed' (see below).
- To adjust the diffuser position:
 - If necessary, adjust distance D using the black adjustment knob located around the oil supply pipe on the front of the burner. Refer to Figure 10-5. Re-check distance D using the gauge plate, as described above.
 - For easier access to the adjustment knob, pull the photocell out from the burner housing.
 - To increase distance D (to open the diffuser): rotate the knob clockwise - indicated as '+' on the knob.
 - To decrease distance D (to close the diffuser): rotate the knob anti-clockwise - indicated as '-' on the knob.

! NOTE !

One full rotation of the adjustment knob is approximately 1mm of diffuser movement.

! NOTE !

It is essential that the final position of the diffuser is checked, using the gauge plate provided with the boiler and the diffuser adjusted as necessary to achieve the required distance D.

9. For Vortex Eco 15/21 and 21/26 models only:
Check the burner air adjuster disc is correctly set. Refer to Section 10.3.

10.3 AIR ADJUSTER DISC: 15/21 AND 21/26 MODELS ONLY

! NOTE !

If the 21/26 model is to be set to 26kW, the air adjuster disc is not required. It should be removed from the burner and discarded.

The Riello RDB 2.2 BX burner fitted to these boilers incorporates a secondary air adjustment.

This is an air adjuster disc located on the fan housing (inside the air inlet housing).

It is essential, for correct operation of the burner, that this internal air adjuster disc is correctly set. Refer to Figure 10-6.

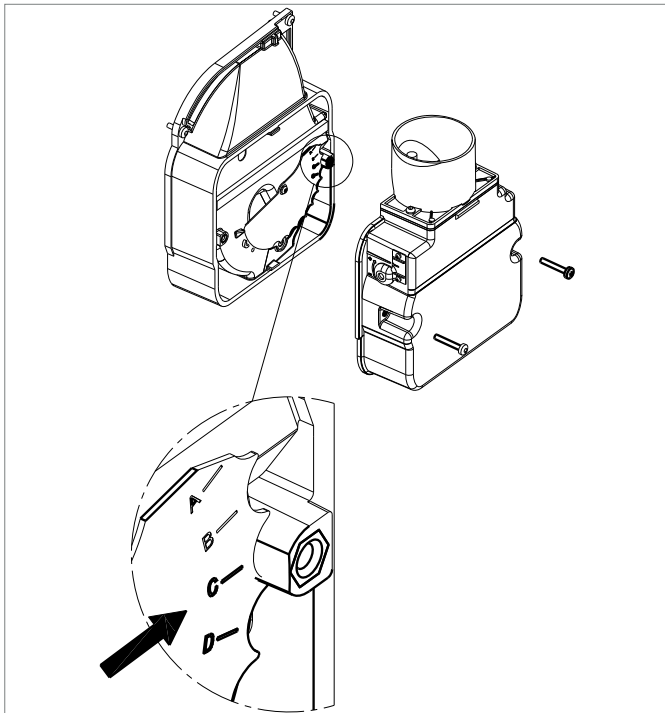

Figure 10-6: Air adjuster disc

To access the air adjuster disc:

1. Ensure the boiler is isolated from the electrical supply.
2. Remove the burner fixing nut (located at the top of the mounting flange) and withdraw the burner from the boiler.
3. Undo the two screws and remove the air inlet cover from the side of the burner.
4. The air adjuster disc is mounted on the fan housing. Refer to Figure 10-6.
5. Check that this disc is correctly set for the factory set output of the boiler, i.e. with the correct cut-out mark located against the moulded boss on the fan housing. Refer to Table 2-3 for correct disc settings. If the disc is not correctly set it MUST be re-positioned. Refer to step 7 below.
6. If the burner is to be set to a different output than the factory setting, the air adjuster disc MUST be set to the required setting for that output. Refer to Table 2-3 for correct disc settings.
7. The air adjuster disc is re-positioned as follows:
 - Remove the screw from the centre of the air adjuster disc.
 - Re-position the disc so that the correct cut-out is located against the moulded boss on the fan housing.
 - Replace the screw in the centre of the air shutter disc and tighten.
8. If the 21/26 model is to be set to 26kW, the air adjuster disc is not required. It should be removed from the burner and discarded.
9. Re-fit the air inlet cover to the side of the burner and secure in place using the two screws.

10.4 SWITCHING ON

1. Check that all system controls are calling for heat and turn the boiler thermostat to maximum.
2. Switch on the electricity supply to the boiler.
3. Set the boiler On/Off switch to ON. A neon on the switch lights when it is in the ON position. The boiler will now light automatically.

Note that the neon lights when the boiler is switched on, but does not necessarily indicate the burner is firing.

The burner should then fire. Open the vent screw on the vent manifold to vent the supply while the oil pump is running

4. The burner fan should start and the burner should light within about 12 seconds. If the burner does not light and the 'Lock-out' reset button on the burner lights, wait about 45 seconds and press the reset button to restart the ignition process.

This procedure may have to be repeated several times during first lighting.

5. With the burner alight, check the fuel pressure. Refer to Section 2.3 (burner settings).
6. Adjust the pressure if necessary - refer to Section 11.8 (burner components).

! NOTE !

It is important that the oil pressure is correctly set.

7. Operate the boiler until it reaches normal operating temperature. Check oil supply/return pipe for leaks, rectifying where necessary.
8. Check the operation of the boiler thermostat. Ensure that by turning it anticlockwise it switches the burner off.
9. With the burner alight, re-check the fuel pressure and re-adjust if necessary. Turn the boiler off, remove the pressure gauge and replace the plug in the pump.
10. Ensure that there are no oil leaks, replace the burner cover.
11. On balanced flue installations - Ensure the flexible air inlet tube is correctly connected to both the burner air inlet and the flue system.

10.5 RUNNING THE BOILER

1. Relight the boiler and allow it to run for at least 20 minutes.
2. Check the smoke number, if it is 0-1 then it is satisfactory.
3. Using a calibrated electronic flue gas analyser, set to the correct fuel, check the %CO₂ in the flue gases.

! NOTE !

To allow the boiler to be commissioned and serviced correctly a combustion test point is provided on the front cleaning door. Both the %CO₂ and smoke test may all be carried out using this test point.

This test point is not suitable for measuring boiler efficiency or conventional flue draught.

4. When using the test point on the cleaning cover note that the flue gas temperature reading will be higher than that measured in the flue thus resulting in an inaccurate efficiency reading. To obtain an accurate flue gas temperature and efficiency, the reading can only be measured outside through the low level flue terminal (or the test point on the conventional flue starter section when used).
5. For high level and vertical balanced flues, the reading may be taken from the flue test point provided on the flue system.
6. For conventional flues, a test point is provided in the conventional flue adaptor for flue draught and flue gas temperature measurement.
7. Set the %CO₂, as indicated on the flue gas analyser, to the required value as given in Section 2.3 for the boiler concerned.
8. Adjust the burner air damper, using the hexagonal key supplied, to achieve the required %CO₂. Refer to Section 11.8.
9. To increase the %CO₂:
 - Turn the screw anti-clockwise. This will close down the burner air damper and decrease the combustion air entering the burner.To decrease the %CO₂:
 - Turn the screw clockwise. This will open up the burner air damper and increase the combustion air entering the burner.
10. When the %CO₂ is set to the correct level, re-check the smoke number if the burner air damper has been moved. Under no circumstances must the smoke number be above 1.

! NOTE !

For safe and efficient operation of the boiler it is essential that the air damper is correctly set to give the required %CO₂ in the flue gases.

10.6 BALANCING THE SYSTEM

1. When the boiler has been adjusted and is running satisfactorily, balance the central heating system by adjusting the radiator lock shield valves. Start with the radiator nearest the boiler and adjust the valves to achieve the required temperature drop across each radiator. If thermostatic radiator valves have been installed, check the system bypass.
2. Switch off the boiler.

10.7 COMPLETION

1. With the system hot, check again for leaks, rectifying where necessary. Drain the system while it is hot to complete the flushing process. Refill and vent the sealed system.
2. A suitable central heating system inhibitor must be added to protect the system against the effect of corrosion.
3. A suitable antifreeze should be used to prevent damage to the boiler in areas where electrical power failure can occur in winter months.
4. Replace the top, front and rear panels as necessary.

! NOTE !

After commissioning the boiler complete the OFTEC CD/11 commissioning report. Leave the top copy with the user and retain the carbon copy.

If the boiler is to be left in service with the User, set the controls and room thermostat (if fitted) to the User's requirements.

If the boiler is not to be handed over immediately, close the boiler fuel supply valve and switch off the electricity supply.

! CAUTION !

If there is any possibility of the boiler being left during freezing conditions, then the boiler and system should be drained. Alternatively, a suitable heating system antifreeze should be used.

10.8 INFORMATION FOR THE USER

The User must be advised (and demonstrated if necessary) of the following important points:-

- How to start and switch off the boiler and how to operate the system controls.
- The precautions necessary to prevent damage to the central heating system and to the building, in the event of the boiler not being in operation during frost conditions.
- The importance of servicing the boiler to ensure safe and efficient operation. This should normally be required only once a year.
- The type of fuel used.
- That any servicing or replacement of parts must only be carried out by a suitably qualified engineer.
- Ensure that the boiler controls and room thermostat (if fitted) are set to the User's requirements.
- Tell the User the system pressure and show them the position of the safety valve discharge pipe.
- Show the User how to reset the overheat thermostat and how to restart the boiler if it goes to 'Lockout'.

11 SERVICING

To ensure safe and efficient operation it is essential that a Grant Vortex Eco boiler is serviced at regular intervals of no longer than 12 months.

Servicing and replacement of parts must only be carried out by a suitably qualified engineer.

! CAUTION !

Details of every service should be entered in the Service Log, in the Boiler Handbook.

This information may be required to validate the Grant extended guarantee.

! WARNING !

Before starting any work on the boiler or fuel supply, please read the Health and Safety information given in Section 15 of these Instructions.

11.1 CHECKS BEFORE SERVICING

The following sequence of checks should be made before starting any servicing work:

1. Check the flue terminal and ensure it is not blocked or damaged.
2. Run the boiler and check the operation of its controls.
3. Ensure that all water system connections and fittings are sound. Remake any joints and check the tightness of any fittings that may be leaking.
4. Allow the boiler and system to cool down.
5. If the boiler is part of a sealed central heating system, check the system pressure, check the operation of the pressure relief valve and check the expansion vessel air charge. Refer to Section 7.
6. Refill, vent and re-pressurise the system as necessary. Refer to Section 7.
7. Check that the ventilation holes in the front casing door are clear of obstructions. See Section 9.
8. Remove any sludge/water from the fuel tank by opening the sludge valve at the lower end of the tank (if fitted).
9. Ensure that all fuel system connections and fittings are sound. Remake any joints and check the tightness of any fittings that may be leaking.
10. With the fuel supply valve (at the oil tank) closed, clean/replace the filter element and clean the filter bowl.

! WARNING !

Before servicing, set the boiler ON/OFF switch to OFF, isolate the electricity supply and close the fuel supply valve.

The data label on the inside of the case side panel will indicate the fuel used and the nozzle fitted.

11.2 DISMANTLING PRIOR TO SERVICING

The procedure for dismantling the boiler is as follows:

1. Remove the front casing door by turning the handle and pulling forward at the bottom.
2. Remove the four screws retaining the top casing panel and carefully lift it off, taking care not to damage the insulation.

! NOTE !

The top panel has been designed to provide a slight fall away from the side positioned against a wall. Please refer to Figure 4-1 for further details.

3. If a system model is being serviced, carefully lift up and remove the expansion vessel from the front of the boiler. Place the vessel on the floor taking care not to strain the expansion vessel hose.
4. Unscrew and remove the two fixing screws and remove the red cover from the burner.
5. Remove the burner fixing nut (located at the top of the mounting flange) and withdraw the burner from the boiler. If required, disconnect the flexible oil line(s), using a suitable container to prevent any oil spillage.
6. Check or replace the flexible fuel supply hose, as follows:
 - Braided flexible fuel supply hoses (as supplied with the boiler) should be replaced annually, i.e. when the boiler is serviced.
 - Long-life hoses should be inspected annually. If in doubt replace the hose(s). In any event, these hoses must be replaced every five years.

! NOTE !

With a two-pipe oil supply there will be two flexible hoses connected to the burner. Identify (mark if necessary) which is the inlet and return if they are to be disconnected.

11.3 CLEANING THE BOILER

The procedure for cleaning the boiler is as follows:

1. Remove the nuts and washers securing the front cleaning door and withdraw the door. Take care - it is heavy.
2. Remove the baffles as shown in Figures 11-1 and 11-2.
3. Remove all deposits from the baffle plates and all the boiler internal surfaces using a stiff brush and scraper if necessary.
4. Check the condition of the flue, clean as necessary.
5. Check the condition of the front cleaning door seal and replace if necessary.
6. Replace the baffles, ensuring they are correctly fitted. Refer to Figures 11-1 and 11-2, as appropriate.
7. Pull out the spiral turbulators from the heat exchanger tubes. See Figure 11-3. Clean the turbulators using a stiff brush.
8. Test the heat exchanger condensate drain by pouring water into one of the lower tubes and observe whether the water discharges from the 22 mm condensate outlet. Replace the turbulators.
9. Replace the front cleaning door, ensuring the seal is in good condition and secure it in position with the nuts and washers previously removed. Tighten to form a seal.
10. Remove the condensate trap and check that it is not blocked and is operating correctly, i.e. the float is free to move. Clean the trap and float as required.
11. Check the condition of the flexible condensate hose between the trap and the boiler.
12. Check that the boiler condensate outlet is unobstructed. Clean if necessary.

! NOTE !

The condensate trap and condensate outlet must be checked on every service and cleaned as necessary.

The end cap is not sealed to the trap body and can be removed for cleaning. Ensure that this cap is correctly re-fitted before re-starting the boiler.

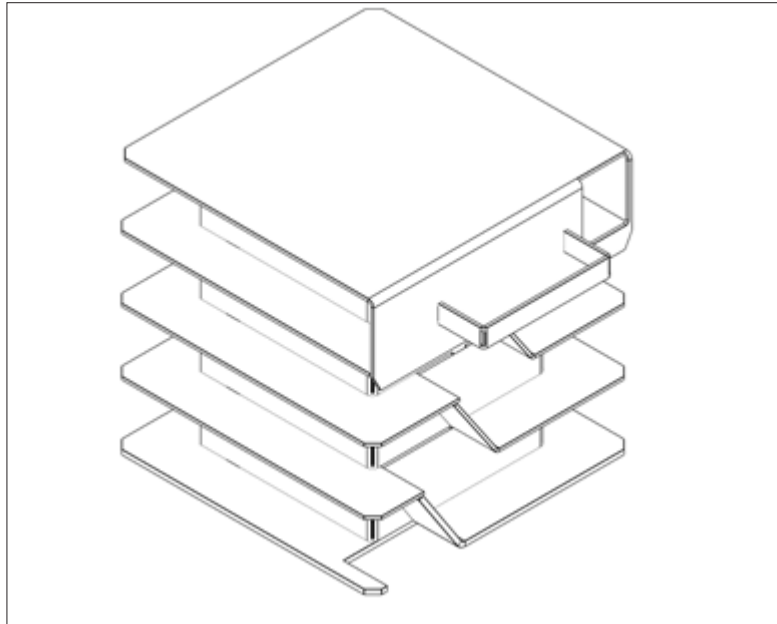

Figure 11-1: Baffles (15/21 & 21/26 models)

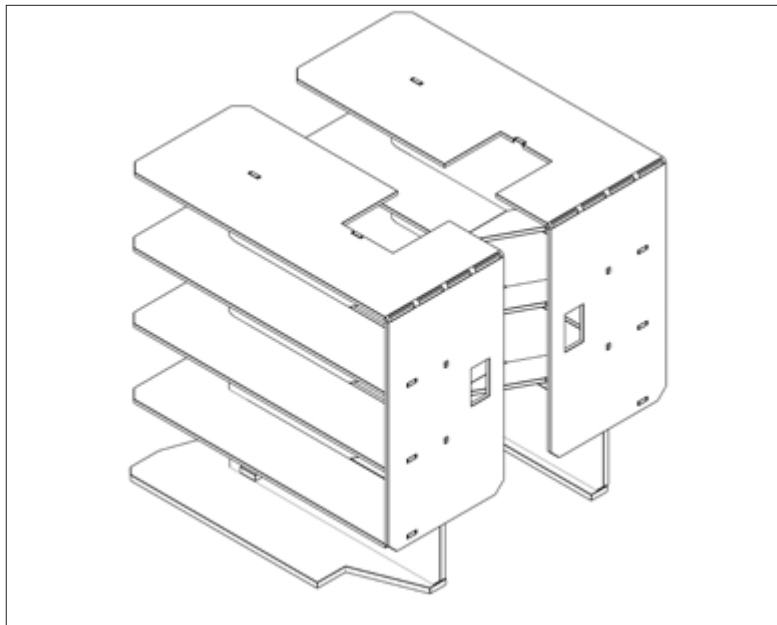

Figure 11-2: Baffles (26/35 models)

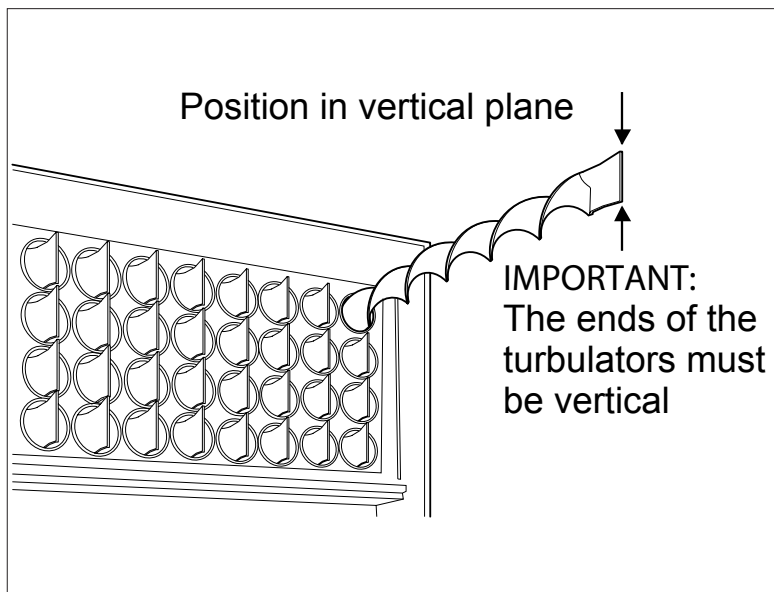

Figure 11-3: Turbulators

11.4 CLEANING THE BURNER: RDB2.2 BX BURNERS

With the burner removed from the boiler:

Burner head, nozzle and diffuser/electrode assembly:

1. Remove the burner head. Refer to Figure 10-3. Loosen the three fixing screws (1) and remove head (2) from burner.
2. Clean the burner head and recirculation tube (if fitted).
3. Remove diffuser/electrode assembly. Refer to Figure 10-3.
 - Using a 4 mm Allen key, loosen the diffuser fixing screw (3) from electrode assembly.
 - Lift diffuser/electrode assembly (5) up and off the nozzle holder.
 - Disconnect both ignition leads (4) from the electrodes.
4. Replace the nozzle (8). The nozzle should always be replaced on an annual service. Refer to Table 2-3 for the correct nozzle size and type for the required boiler output. Do NOT attempt to clean the nozzle.

Use a 16 mm spanner to remove/re-fit the nozzle, whilst holding the nozzle holder (6) using a 19 mm spanner.

! CAUTION !

The use of an ill-fitting spanner will damage the nozzle and could lead to an incorrect flame pattern and poor combustion.

! NOTE !

Ensure that the nozzle is securely tightened so that it does not leak but do not overtighten.

5. Inspect the ignition electrodes - remove the diffuser fixing screw and withdraw the electrode assembly. Wipe clean and check for any cracks in the ceramic insulation. Replace if necessary.
6. Re-fit the diffuser/electrode assembly. Refer to Figure 10-3.
 - Reconnect ignition leads (4) to electrodes.
 - Re-fit the diffuser/electrode assembly (5) onto the nozzle holder lining up the fixing screw with the recess in the nozzle holder.
 - Ensure diffuser assembly is fitted down hard onto the shoulder on the nozzle holder.
 - Tighten the fixing screw (3) to secure the diffuser/electrode assembly in place on the nozzle holder.

! NOTE !

Do not overtighten the fixing screw as this may damage the electrode insulator.

7. Check/adjust the electrode settings. Refer to Figure 10-4. Always check the electrode settings after replacing the nozzle.
8. Re-fit the burner head. Refer to Figure 10-3.
 - Locate the head fixing screws (1) in the countersunk slots in the burner collar.
 - Check that the small oil drip hole (on the head) is pointing downwards.
 - Tighten the three screws (1) to secure the head (2) in position on the burner.
9. Adjust the diffuser position. Refer to Section 11-5.

Photocell

The photocell is a push-fit in the front of burner body. Refer to Sections 11.8.

1. Holding the body of the photocell and NOT the cable, carefully pull the photocell out of the burner.
2. Clean the sensor end of the photocell.
3. Replace photocell back in the burner and check that it is fully pushed in.

Burner air inlet cover

This is located on the right hand side of the burner. Refer to Section 11.8.

1. Unscrew and remove the two screws and remove the air inlet cover from the burner.
2. Check inside and remove any debris, leaves, hair, fluff, etc. from the air inlet cover and air damper.
3. Check the condition of the rubber seal around the air inlet cover. Replace if damaged or missing.

Burner fan housing

This is located over the fan impeller. Refer to Section 11.8.

With the burner air inlet cover already removed:

1. Unscrew and remove the four screws and remove the fan housing from the burner.
2. Check and clean the fan impeller and remove any debris, leaves, hair, fluff etc.
3. Check the fan housing is clean and clean as required.
4. Check the rubber seal around the fan housing. Replace if damaged or missing.
5. Re-fit the fan housing to the burner and secure with the four screws.
6. Check the air adjuster disc (15/21 and 21/26 models only). Refer to Section 10.3 for details.
7. Re-fit the air inlet cover to the burner and secure with the two screws.

Oil pump filter

This is located under the end cover on the oil pump. Refer to Section 11.8.

1. Unscrew and remove the four cap screws securing the pump end cover.
2. Remove the filter and wash in kerosene.
3. Check the O-ring seal around the end cover. Replace if damaged.
4. Replace the filter and end cover.
5. Re-fit the four cap screws, tightening evenly, to secure the end cap.

11.5 ADJUSTING THE DIFFUSER

Adjust the diffuser position. Refer to Figure 10-5.

! NOTE !

The distance between the end of the burner head and the front face of the diffuser (D) MUST be correctly set for the burner to operate correctly.

- Refer to Table 2-3 for the required distance (head setting) for the boiler output required.
- Check the distance D using the gauge plate supplied with the boiler.
- To use the gauge plate:
 - Position the gauge on the burner head as shown in Figure 10-5.
 - Locate the gauge with the correct steps (i.e. the two marked with the required distance D) resting on the edge of the burner head.
 - Check the gauge plate is at 90° to the end of the burner head and is positioned at the full diameter of the head.
 - If the distance D is correct, the tongue of the gauge should just make contact with the diffuser, with BOTH steps still in contact with the edge of the burner head.
 - If the steps are not in contact with the edge of the burner head, when the tongue of the gauge is touching the diffuser, the diffuser must be 'opened' (see below).
 - If the tongue does not reach the diffuser, when the steps are in contact with the edge of the burner head, the diffuser must be 'closed' (see below).
- To adjust the diffuser position:
 - If necessary, adjust distance D using the black adjustment knob located around the oil supply pipe on the front of the burner. Refer to Figure 10-5. Re-check distance D using the gauge plate, as described above.
 - For easier access to the adjustment knob, pull the photocell out from the burner housing.
 - To increase distance D (to open the diffuser): rotate the knob clockwise - indicated as '+' on the knob.
 - To decrease distance D (to close the diffuser): rotate the knob anti-clockwise - indicated as '-' on the knob.

! NOTE !

One full rotation of the adjustment knob is approximately 1 mm of diffuser movement.

! NOTE !

It is essential that the final position of the diffuser is checked, using the gauge plate provided with the boiler and the diffuser adjusted as necessary to achieve the required distance D.

11.6 AIR ADJUSTER DISC: 15/21 AND 21/26 MODELS ONLY

Refer to Section 10.3.

11.7 RECOMMISSIONING

! WARNING !

To ensure safe and efficient operation of the boiler it is important that re-commissioning is carried out, especially combustion checks (%CO₂ level, flue gas temperature and smoke number) after the boiler has been serviced. Refer to the Commissioning instructions in Section 10.

**11.8 BURNER COMPONENTS
RDB2.2 BX BURNERS**

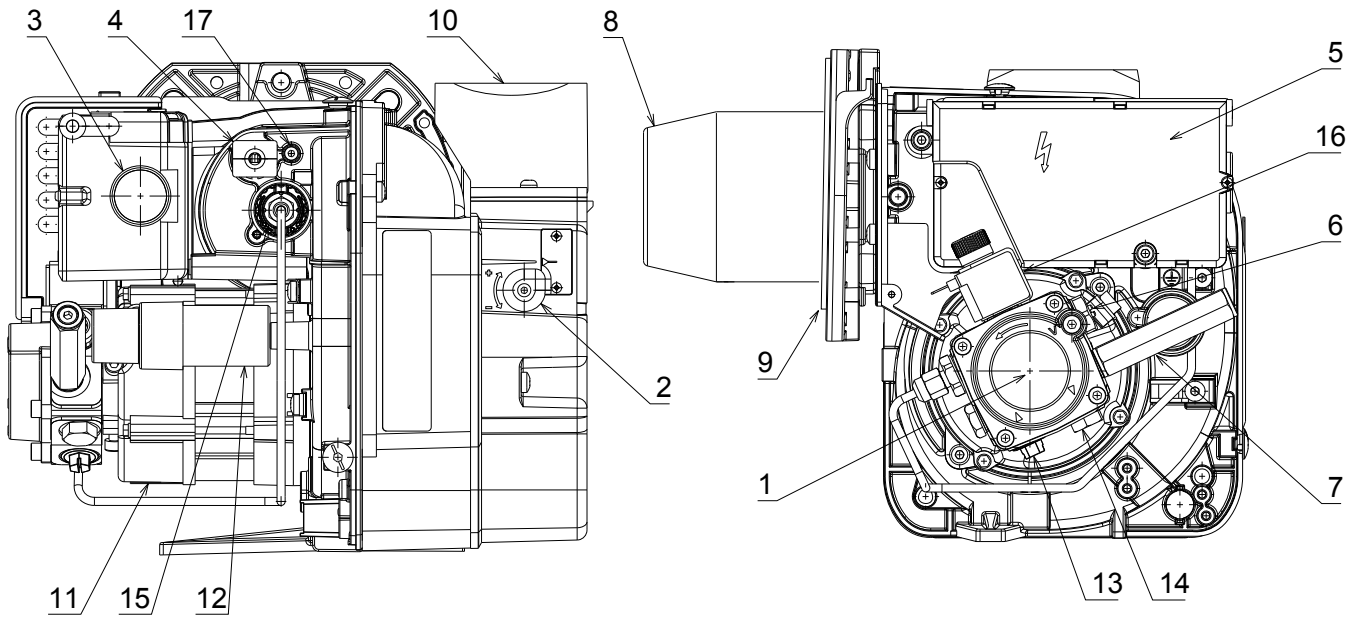

Item	Description	Item	Description
1	Oil pump	10	Air inlet
2	Air damper adjustment screw	11	Motor
3	Reset button with lockout lamp	12	Motor ignition capacitor
4	Photocell	13	Fuel suction line
5	Control box	14	Return line
6	Pump pressure adjustment screw	15	Combustion head adjustment handle
7	Extension for gauge connection	16	Coil
8	Combustion head	17	Air pressure test point
9	Flange with insulating gasket		

12 FAULT FINDING

12.1 BOILER FAULT FINDING

Always isolate the electricity supply to the boiler before working on the boiler.

Table 12-1: Boiler fault finding

Fault	Remedies
Boiler will not start:	
No fuel supply.	Ensure that an adequate supply of fuel is available and that the fuel supply valve is open. Check the condition of the fuel filter, clean if necessary. Ensure fuel supply is reaching burner and vent pump. Check that the fire valve has not operated to shut off the oil supply.
No electricity supply.	Ensure electricity supply to the boiler is switched on and that all controls are calling for heat. Ensure that the overheat thermostat has not tripped, reset if necessary. Check that a mains supply is present at the burner terminal block. If not, check the boiler and overheat thermostat.
Burner not starting - fuel and electricity supplies present.	Press the reset button on the burner control box if it is lit. Refer to burner fault finding charts.
Burner lights but goes to lock-out.	If the flame is unstable, check the combustion settings. Refer to burner fault finding charts.
Boiler works but:	
1. Visible smoke from flue or high smoke number.	Insufficient air supply - check the air damper setting and the condition of the fan. Check room ventilation is adequate, see Section 9.1. Check the nozzle size and type. Fuel pressure may be too high - check and adjust.
2. Burner pulses.	Insufficient air supply - check the air damper setting and the condition of the fan. Check room ventilation is adequate, see Section 9.1. Check the nozzle size and type.
3. Flame slow to stabilise during start up.	Insufficient air supply - check the air damper setting and the condition of the fan. Check room ventilation is adequate, see Section 9.1. Check the nozzle size and type. Fuel pressure may be too low - check and adjust. Insufficient draught - clean boiler heat exchanger and check condition of flue.
4. Water temperature low.	Undersized nozzle and/or low fuel pressure. Check condition of boiler heat exchanger and clean if necessary. Check the boiler thermostat. Check the combustion settings. Check the condition of the fuel filter.
5. Boiler operating on overheat thermostat.	Faulty boiler thermostat. No circulation, check circulating pump. Check for air lock.
6. Fumes and puffing during starting (conventional flue)	Check the condition of the chimney, ensure it is not blocked and is high enough to produce the required draught. Check that there is an adequate air supply near the burner and that a kitchen fan is not drawing products out of the burner.
7. Oil odours.	Check all fuel line connections, remake as necessary.
8. Combustion fumes smell.	Check boiler cleaning cover and seal are correctly fitted. Check burner is correctly fitted onto flange. Check flue is correctly sealed into flue outlet of boiler. Check the condensate pipe and trap are operating correctly.

! NOTE !

For an overview of the fault diagnostic capabilities built into the circulating pumps that come installed in the sealed system boiler models, please refer to Appendix A1 or A2, as required, at the back of this installation and servicing manual.

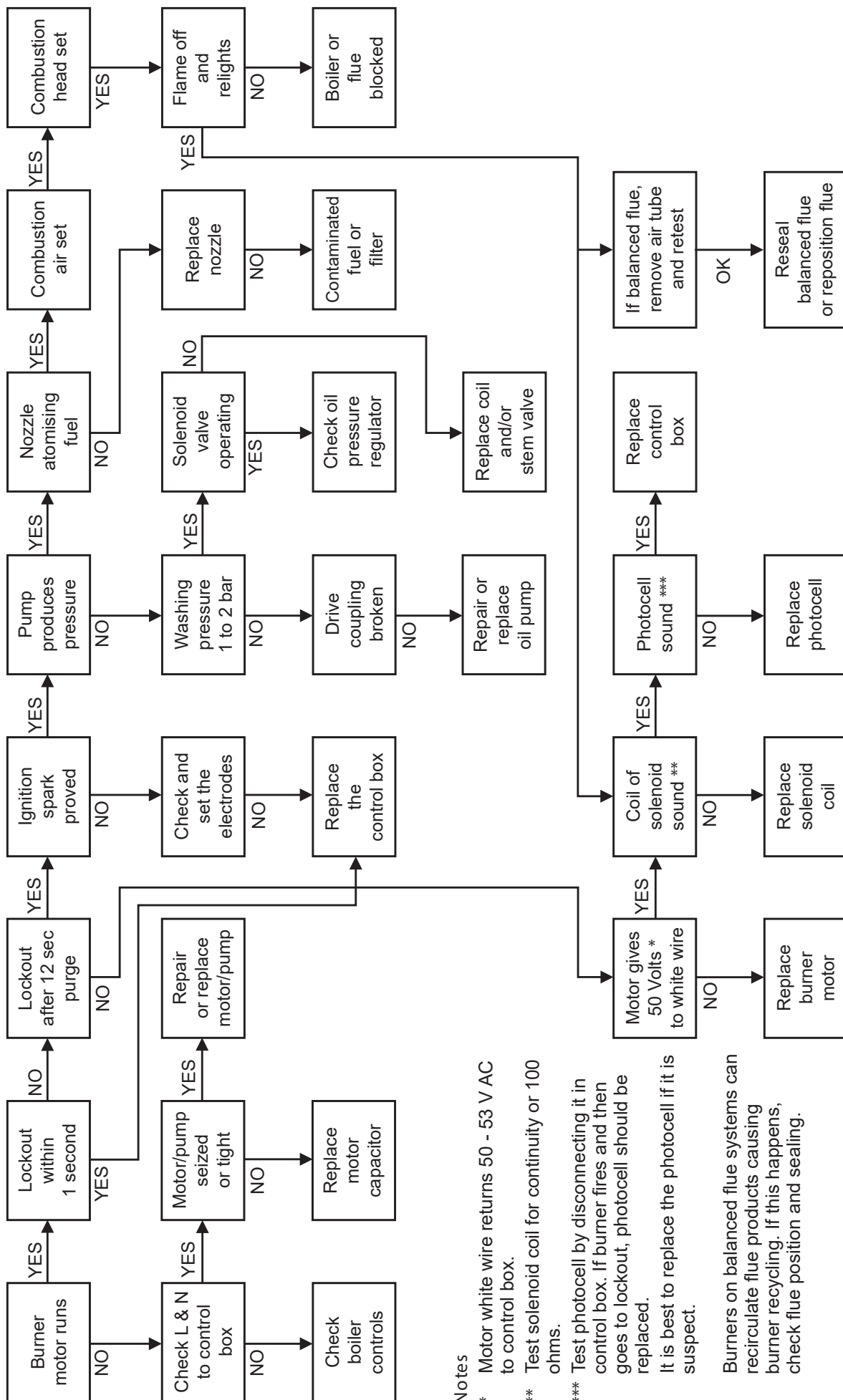

Notes

- * Motor white wire returns 50 - 53 V AC to control box.
- ** Test solenoid coil for continuity or 100 ohms.
- *** Test photocell by disconnecting it in control box. If burner fires and then goes to lockout, photocell should be replaced. It is best to replace the photocell if it is suspect.

Burners on balanced flue systems can recirculate flue products causing burner recycling. If this happens, check flue position and sealing.

13 SPARE PARTS

13.1 BOILER PARTS LIST

Table 13-1: Boiler parts list

Description	Grant UK product code
Cleaning door nut and washer set	EFBS14
Double pole switch	EFBS19
Baffle set (complete) - 15/21 & 21/26	VBS96
Baffle set (complete) - 26/35	VBS97
Turbulator baffle - 360 mm (single) - all models	VBS05
Combustion Door - 15/21 and 21/26	VBS92
Combustion Door - 26/35	VBS69
Cleaning door rope seal - 15/21 and 21/26	VBS15
Cleaning door rope seal - 26/35	VBS16
Limit thermostat (110°C) c/w Earth wire	VBS147
Control thermostat (50 - 75°C) c/w Earth wire	VBS146
Wilo SE circulating pump (6 m head) - all System models Pre April 2015	MPCBS43*
Wilo Yonos Para RKC HE circulating pump (7 m head) - all System models between April 2015 and November 2019	VBS126
Wilo Para SC HE circulating pump (7m head) - all System models from November 2019	VBS159
Automatic Air Vent	MPCBS29
Low Pressure Switch Upgrade Kit (all external models)	MPCBS63/A

* Standard efficiency pumps should only be installed when a high efficiency pump is not compatible

13.2 SEALED SYSTEM PARTS LIST

Table 13-2: Sealed system parts list

Description	Grant UK product code
Expansion vessel (12 litre) - all models	MPSS01
Water pressure gauge	VBS08
Pressure relief valve (3.0 bar)	MPCBS123
Pressure relief valve with pressure gauge port (3.0 bar)	MPCBS124
Expansion vessel flexible hose	MPCBS79
Filling Loop Kit	VBS35X

Table 13-3: Riello RDB 2.2 BX burner parts list - 15/21, 21/26 and 26/35 models

Key No.	15/21	21/26	26/35	Description	Riello product code	Grant product code
1	•	•	•	Flange gasket	3005787	Z3005787
2	•	•	•	Combustion head (burner serial No. ≤ 02098013XXX)	20076038	Z20076038
	•	•	•	Combustion head (burner serial No. ≥ 02108013XXX)	20147320	Z20147320
3	•	•	•	Electrode	20018545	Z20018545
	•	•	•	Electrode	20018693	Z20018693
	•	•	•	Diffuser disc	20139837	Z20139837
4	•	•	•	Diffuser disc	20133586	Z20133586
	•	•	•	Nozzle holder	20133588	Z20133588
6	•	•	•	Collar (burner serial No. ≤ 02098013XXX)	20133590	Z20133590
	•	•	•	Collar (burner serial No. ≥ 02108013XXX)	20141540	Z20141540
7	•	•	•	High voltage lead	20019415	Z20019415
	•	•	•	Air damper assembly	20089768	Z20089768
	•	•	•	Air damper assembly	3008839	Z3008839
9	•	•	Fan	3005788	Z3005788	
10	•	•	Flame sensor	20132526	Z20132526	
11	•	•	Capacitor	20071576	Z20071576	
12	•	•	Needle valve	3007871	Z3007871	
13	•	•	Regulator	3008651	Z3008651	
14	•	•	Air damper	20094349	Z20094349	
15	•	•	Pump	20030953	Z20030953	
16	•	•	O-ring	3007175	Z3007175	
17	•	•	O-ring and filter	3020436	Z3020436	
18	•	•	Connector	3003602	Z3003602	
19	•	•	Hose	3005720	Z3005720	
20	•	•	Tube	20018549	Z20018549	
21	•	•	Extension	3008876	Z3008876	
22	•	•	Coupling	3000443	Z3000443	
23	•	•	Coil	3008648	Z3008648	
24	•	•	Motor and capacitor	20071577	Z20071577	
25	•	•	Protection	3008649	Z3008649	
26	•	•	Control box	3008652	Z3008652	

Continued on next page

Table 13-3: Riello RDB 2.2 BX burner parts list - 15/21, 21/26 and 26/35 models (continued)

Key No.	15/21	21/26	26/35	Description	Riello product code	Grant product code
27	•	•	•	Connection	3008851	Z3008851
28	•	•	•	Seals kit	20040600	Z20040600
29	•	•	•	Front shield	3020306	Z3020306
30	•	•	•	Air intake	3020281	Z3020281
31	•	•	•	Bulkhead	20081612	Z20081612
32	•	•	•	Front piece	3006384	Z3006384
33	•	•	•	Cover	3008879	Z3008879
34	•	•	•	Shell and knob	3007566	Z3007566
35	•	•	•	Screw	20119098	Z20119098
36	•	•	•	Bypass screw	20029299	Z20029299
37	•	•	•	Connector	3020076	Z3020076
38	•	•	•	Knob	30134372	Z30134372
39	•	•	•	Connection	20140287	Z20140287
40	•	•	•	Seal	3007087	Z3007087
41	•	•	•	Seal	3020086	Z3020086
42	•	•	•	O-ring	3007177	Z3007177
43	•	•	•	O-ring seal	3007028	Z3007028
44	•	•	•	O-ring	3007167	Z3007167
45	•	•	•	O-ring	3007178	Z3007178
46	•	•	•	Coil	3007565	Z3007565
47	•	•	•	Index	20147023	Z20147023
48	•	•	•	Gauge	20148209	Contact Grant UK
49	•	•	•	Conventional Flue Air Intake	20012046	Z20012046

14 DECLARATION OF CONFORMITY

EC DECLARATION OF CONFORMITY

In accordance with BS EN ISO/IEC 17050-1:2004

We: Grant Engineering (UK) Limited

Of: Hopton House
Hopton Industrial Estate
Devizes
SN10 2EU

Telephone: +44 (0)1380 736920

Fax: +44 (0)1380 736991

Email: info@grantuk.com

Website: www.grantuk.com

Declare that:

Equipment: Domestic oil boilers

Model Name/Number: Grant Vortex Eco External 15-21, 21-26 and 26-35
Grant Vortex Eco External System 15-21, 21-26 and 26-35

Note: All Grant system variants are supplied with glandless high efficiency integrated circulators

In accordance with the following Directives:

2006/95/EEC Conforms with the safety objectives of the Low Voltage Directive and its amending directives.

2004/108/EC Conforms with the essential protection requirements of the Electromagnetic Compatibility Directive and its amending directives.

92/42/EC Conforms with the requirements of the Boiler Efficiency Directive.

2010/30/EU Conforms with the Labeling of Energy related products to EU (no) 811/2013

2009/125/EC Conforms with the Ecodesign of Energy related products to EU (no) 813/2013

I hereby declare that the equipment named above has been tested and found to comply with the relevant sections of the above referenced specifications. The unit complies with all essential requirements of the Directives.

Responsible Person: Neil Sawers

Position: Technical Manager

Signature:



Date: November 2018

15 HEALTH AND SAFETY INFORMATION

Under the Consumer Protection Act 1987 and Section 6 of the Health & Safety at Work Act 1974, we are required to provide information on substances hazardous to health (COSHH Regulations 1988).

Adhesives, sealants and paints used in the manufacture of the product are cured and present no known hazards when used in the manner for which they are intended.

The following other materials are present in the product:

15.1 INSULATION MATERIALS

Material Types:

Ceramic fibre board, mineral wool.

Description:

Rigid board, slabs, sleeves, gaskets, ropes.

Known Hazards:

May cause temporary irritation or rash to skin. High dust levels may irritate eyes and upper respiratory system.

Precautions:

Avoid unnecessary or rough handling, or harsh abrasion of boards. Normal handling and use of material should not produce high dust levels.

Avoid inhalation, and contact with skin and eyes.

After handling always follow normal good hygiene practices.

Protection:

Use disposable gloves, face mask and eye protection.

First Aid:

Eyes - If irritation occurs, wash eyes with copious amounts of water.

If symptoms persist, seek immediate medical advice.

Skin

If irritation occurs, wash under running water before washing with soap and water.

Inhalation

Remove to fresh air, drink water to clear throat and blow nose to remove dust/fibres.

Ingestion

Drink plenty of water.

15.2 SEALANT AND ADHESIVE

Material Types:

Silicone elastomer.

Description:

Sealant and adhesive.

Known Hazards:

Irritation to eyes.

Precautions:

Avoid inhalation of vapour, contact with eyes and prolonged or repeated contact with skin.

After handling always follow normal good hygiene practices.

Protection:

Use eye protection. Rubber or plastic gloves should be worn where repeated contact occurs and a face mask worn when working in confined spaces.

First Aid:

Eyes

Flush eyes with water for 15 minutes. Seek immediate medical attention.

Skin

Wipe off and wash with soap and water.

Inhalation

Remove to fresh air.

15.3 KEROSENE AND GAS OIL FUELS (MINERAL OILS)

Known Hazards:

The effect of mineral oils on the skin vary according to the duration of exposure and the type of oil.

The lighter fractions remove the protective grease naturally present on the skin, leaving it dry, liable to crack and more prone to damage by cuts, abrasions and irritant chemicals.

Skin rashes (Oil acne) most often on arms, but also on any part of the body in contact with oil or oily clothing.

Contact with fuel oils can cause dermatitis.

Precautions:

Avoid as far as possible any skin contact with mineral oil or with clothing contaminated with mineral oil.

The use of a lanolin-based barrier cream is recommended, in conjunction with regular washing with soap and rinsing with water to ensure all oil is removed from the skin.

Take care to prevent clothing, especially underwear, from becoming contaminated with oil.

Do not put oily rags or tools in pockets, especially trouser pockets.

Have first-aid treatment at once for an injury, however slight.

Do not inhale any vapours from mineral oils.

16 END OF LIFE INFORMATION

GENERAL

Grant oil boilers incorporate components manufactured from a variety of different materials. The majority of these materials can be recycled whilst the smaller remainder cannot.

Materials that cannot be recycled must be disposed of according to local regulations using appropriate waste collection and/or disposal services.

DISASSEMBLY

There is little risk to those involved in the disassembly of this product. Please refer to and follow the Health and Safety Information given in the Installation & Servicing Instructions provided with the boiler.

For guidance on the disassembly of the boiler refer to the information given in the Servicing section of the Installation & Servicing Instructions provided with the boiler.

RECYCLING

Many of the materials used in Grant oil boilers can be recycled, these are listed in the table below:

COMPONENT	MATERIAL
Outer casing panels	Mild steel (polyester powder coated)
Primary heat exchanger and baffles	Mild steel
Secondary heat exchanger	Stainless steel
Secondary heat exchanger spirals	Aluminium alloy
Pipework	Copper
Burner body/flange	Aluminium alloy
Burner oil pump	Aluminium alloy/steel
Riello oil burner cover	Plastic
Electrical wiring	Copper/plastic
Thermostats	Copper/plastic
Printed Circuit boards	Copper/plastic

DISPOSAL

All materials other than those listed above must be disposed of responsibly as general waste.



Neil Sawers
Technical Manager

17 PRODUCT FICHE

Product fiche concerning the
 COMMISSION DELEGATED REGULATIONS
 (EU) No 811/2013 of 18 February 2013
 (EU) No 813/2013 of 2 August 2013

Vortex Eco External	Symbols	Unit	Eco External 15/21	Eco External 21/26	Eco External 26/36	Eco External System 15/21	Eco External System 21/26	Eco External System 26/35
Condensing boiler			Yes	Yes	Yes	Yes	Yes	Yes
Low temperature boiler			No	No	No	No	No	No
B1 boiler			No	No	No	No	No	No
Combination heater			No	No	No	No	No	No
Rated heat output	Prated	kW	21	26	35	21	26	35
Useful heat output								
At rated heat output and high temperature regime	P_4	kW	21	26	35	21	26	35
At 30% of rated heat output and low temperature regime	P_1	kW	6.3	7.8	10.5	6.3	7.8	10.5
Auxiliary electricity consumption								
At full load	elmax	kW	0.113	0.154	0.146	0.113	0.154	0.146
At part load	elmin	kW	0.035	0.047	0.045	0.035	0.047	0.045
In standby mode	P_{SB}	kW	0	0	0	0	0	0
Useful efficiency								
Seasonal space heating energy efficiency	η_s	%	92.68	91.67	92.40	92.68	91.67	92.40
At rated heat output and high temperature regime	η_4	%	95.60	92.40	92.40	95.60	92.40	92.40
At 30% of rated heat output and low temperature regime	η_1	%	98.40	97.20	97.50	98.40	97.20	97.50
Other items								
Standby heat loss	P_{stby}	kW	0.082	0.091	0.090	0.082	0.091	0.090
Ignition burner power consumption	P_{ign}	kW	0	0	0	0	0	0
Annual energy consumption	Q_{HE}	kWh	-	-	-	-	-	-
Sound power level indoors	L_{WA}	dB	51	51	54	51	51	54
Emissions of nitrogen oxides	NO_x	mg/ kWh	<120	<120	<120	<120	<120	<120
Emission class			2	2	2	2	2	2
Daily fuel consumption	Q_{fuel}	kWh	-	-	-	-	-	-
Annual fuel consumption	AFC	GJ	-	-	-	-	-	-

18 GUARANTEE

You are now the proud owner of a Grant Vortex condensing boiler from Grant Engineering (UK) Limited which has been designed to give years of reliable, trouble free operation.

Grant Engineering (UK) Limited guarantees the manufacture of the boiler including all electrical and mechanical components for a period of **twelve months from the date of installation**⁴, provided that the boiler has been installed in full accordance with the installation and servicing instructions issued.

This will be extended to a total period of **two years** if the boiler is registered with Grant Engineering (UK) Limited within **thirty days of installation** and it is serviced at twelve month intervals³. See main Terms and Conditions below.

Registering the product with Grant Engineering (UK) Limited

Please register your Grant Vortex condensing boiler with Grant Engineering UK Limited **within thirty days of installation**. To do so visit:

www.grantuk.com/support/product-registration

You can register your boiler for a further **twelve months** guarantee (giving **two years** from the date of installation⁴). This does not affect your statutory rights¹.

If a fault or defect occurs within the manufacturer's guarantee period

If your boiler should fail within the guarantee period, you must contact Grant Engineering (UK) Limited who will arrange for the repair under the terms of the guarantee, providing that the boiler has been correctly installed, commissioned and serviced (if the appliance has been installed for more than twelve months) by a competent person and the fault is not due to tampering, running out of oil, oil contamination, debris, system water contamination, misuse, trapped air or the failure of any external components not supplied by Grant Engineering (UK) Limited, e.g. fire valve, motorised valve, etc.

This two year guarantee only applies if the boiler is registered with Grant Engineering (UK) Limited within thirty days of installation⁴ and is serviced after twelve months³.

In the first instance

Contact your installer or commissioning engineer to ensure that the fault does not lie with the system components or any incorrect setting of the system controls that falls outside of the manufacturer's guarantee otherwise a service charge could result. Grant Engineering (UK) Limited will not be liable for any charges arising from this process.

If a fault covered by the manufacturer's guarantee is found

Ask your installer to contact Grant Engineering (UK) Limited Service Department on +44 (0)1380 736920 who will arrange for a competent service engineer to rectify the fault.

Remember - before you contact Grant Engineering (UK) Limited

- Ensure the boiler has been installed, commissioned and serviced by a competent person in accordance with the installation and servicing instructions.
- Ensure there is oil to supply the burner.
- Ensure the problem is not being caused by the heating system or its controls. Consult the boiler handbook for guidance.

Free of charge repairs

During the **two year** guarantee period no charge for parts or labour will be made provided that the boiler has been installed and commissioned correctly in accordance with the manufacturer's installation and servicing instructions, it was registered with Grant Engineering (UK) Limited within thirty days of installation⁴ and, for boilers over twelve months old, details of annual service is available³.

The following documents must be made available to Grant Engineering (UK) Limited on request:

- Proof of purchase
- CD10 Installation Completion Form (or equivalent document)
- CD11 Commissioning Report Form (or equivalent document)
- Service documents (CD11 or equivalent document)

Chargeable repairs

A charge may be made (if necessary following testing of parts) if the breakdown is due to any fault(s) caused by the plumbing or heating system, e.g. contamination of parts due to system contamination, sludge, scale, debris or trapped air. Refer to 'Extent of manufacturer's guarantee'.

Extent of manufacturer's guarantee

The manufacturer's guarantee does NOT cover the following:

- If the boiler has been installed for over **two years**.
- If the boiler has not been installed, commissioned, or serviced by a competent person in accordance with the installation and servicing instructions.
- Instances where the serial number has been removed or made illegible.
- Fault(s) due to accidental damage, tampering, unauthorised adjustment, neglect, misuse or operating the boiler contrary to the manufacturer's installation and servicing instructions.
- Damage due to external causes such as bad weather conditions (flood, storms, lightning, frost, snow, or ice), fire, explosion, accident or theft.
- Fault(s) due to incorrectly sized expansion vessel(s), incorrect vessel charge pressure or inadequate expansion on the system.
- Fault(s) caused by external electrics and external components not supplied by Grant Engineering (UK) Limited.
- Problems caused by lack of oil or faults with the oil storage and supply system.
- Fault(s) due to contamination of the oil storage and supply system, e.g. water or debris.
- Bleeding or removing oil storage tank contamination or blockages from oil lines.
- Problems due to the flue system being incorrectly fitted or not installed to meet installation requirements.
- Boiler servicing, de-scaling or flushing.
- Cleaning out condensate traps/discharge pipes or thawing out frozen condensate pipework.
- Checking and replenishing system pressure.
- Oil supply pipelines, electrical cables and plugs, external controls not supplied by Grant Engineering (UK) Limited.
- Heating system components, such as radiators, pipes, fittings, pumps and valves not supplied by Grant Engineering (UK) Limited.
- Instances where the oil boiler has been un-installed and re-installed in another location.
- Use of spare parts not authorised by Grant Engineering (UK) Limited.
- Consumable items including, but not limited to, oil nozzles, oil hoses, gaskets and seals.

IMPORTANT

The nozzle and braided oil hose supplied with the boiler are only covered for the period up to the time of the first service (twelve months). Both **must** be changed on the first service and on every annual service thereafter.

IMPORTANT

A suitable oil filter with a minimum 15µ filtration **must** be installed in the oil supply line.

Do not wait until the fuel supply runs out before you re-order. Sludge in the bottom of the tank may be drawn into the fuel lines. It is recommended that the boiler is switched off when the new oil supply is delivered and that the fuel is allowed to settle for an hour before restarting the boiler.

Terms of manufacturer's guarantee

- The Company shall mean Grant Engineering (UK) Limited.
- The boiler must be installed by a competent person and in full accordance with the relevant Codes of Practice, Regulations and Legislation in force at the time of installation.
- The boiler is guaranteed for **two years** from the date of installation⁴, providing that every twelve months the annual service has been completed³ and the boiler registered with the Company within thirty days of installation. Any work undertaken must be authorised by the Company and carried out by a competent service engineer.
- This guarantee will be invalid if the boiler does not have an annual (every twelve month) service and will then be limited to twelve months from the date of installation⁴.
- The shell (heat exchanger) of the oil boiler is covered by a **five year parts and labour** guarantee from the date of installation⁴. This is subject to the following:
 - The boiler is operated correctly, in accordance with the Installation and servicing instructions.
 - Grant Engineering (UK) Limited **strongly recommends** that a Grant Mag-One in-line magnetic filter/s (or equivalent⁵) is fitted in the heating system pipework. This should be installed and regularly serviced in accordance with the filter manufacturer's instructions. We reserve the right to ask for proof of installation – failure to provide this may result in the guarantee becoming invalid.
 - Proof is provided that the system has been flushed or chemically cleaned where appropriate (refer to BS 7593) and that the required quantity of a suitable corrosion inhibitor added.
 - Proof of annual servicing (including the checking of any expansion vessels and pressure relief valves) must be provided if and when requested by the Company.
- This guarantee does not cover breakdowns caused by incorrect installation, neglect, misuse, accident or failure to operate the boiler in accordance with the manufacturer's installation and servicing instructions.
- The boiler is registered with the Company within thirty days of installation. Failure to do so does not affect your statutory rights¹.
- The balance of the guarantee is transferable providing the installation is serviced prior to the dwelling's new owners taking up residence. Grant Engineering (UK) Limited must be informed of the new owner's details.
- The Company will endeavour to provide prompt service in the unlikely event of a problem occurring, but cannot be held responsible for any consequences of delay however caused.
- This guarantee applies to Grant Engineering (UK) Limited boilers purchased and installed on the UK mainland, Isle of Wight, Channel Islands, Isle of Man and Scottish Isles only². Provision of in-guarantee cover elsewhere in the UK is subject to agreement with the Company.
- All claims under this guarantee must be made to the Company prior to any work being undertaken. Invoices for call out/repair work by any third party will not be accepted unless previously authorised by the Company.
- Proof of purchase and date of installation, commissioning and service documents must be provided on request.
- If a replacement boiler is supplied under the guarantee (due to a manufacturing fault) the product guarantee continues

from the installation date of the original boiler and **not** from the installation date of the replacement⁴.

- The oil boiler must be connected to a mains water supply (installations utilising a private water supply are not covered by this guarantee).
- Breakdown/failure due to lime scale will not be covered by this guarantee.
- The replacement of a boiler under this guarantee does not include any consequential costs, such as the removal or replacement of worktops, kitchen units, etc.
- The boiler (excluding external modules) must not be sited in a location where it may be subjected to frost.

Hard water advice (for Combi boilers only)

If you live in a hard water area, protection against scaling must be given to the domestic hot water heat exchanger of your combination boiler.

You should fit an appropriate scale inhibitor or water softener as any breakdown caused by water scaling is not covered by the manufacturer's guarantee. Ask your installer for advice.

Foot notes

1. Your statutory rights entitle you to a one year guarantee period only.
2. The UK mainland consists of England, Scotland and Wales only. Please note that for the purposes of this definition, Northern Ireland and Scilly Isles are **not** considered part of the UK mainland.
3. We recommend that your oil boiler is serviced every twelve months (even when the guarantee has expired) to prolong the lifespan and ensure it is operating safely and efficiently.
4. The guarantee period will commence from the date of installation, unless the installation date is more than six months from the date of purchase, in which case the guarantee period will commence six months from the date of purchase.
5. As measured by gauss. The MagOne magnetic filter has a gauss measurement of 12,000.

Version 1.2 – February 2017

APPENDIX A1 WILO YONOS PARA RS RKC CIRCULATING PUMP

A1.1 WILO YONOS PARA RS RKC CIRCULATING PUMP

A1.1.1 PUMP SPECIFICATION

Table A1-1: Pump specification

Make and model	Wilо Yonos PARA RS 15/7.0 RKC FS 130 12
Construction	
Pump housing	Cast iron (with cataphorisis treatment)
Impellar	PP composite with GF 40%
Pump shaft	Stainless Steel
Bearing	Carbon, metal impregnated
Protection Class	IPx4D
Insulation Class	F
Motor Protection	Integrated
Performance	
Max. delivery head	7.2m @ Q = 0 m ³ /h
Max. volume flow	3.3 0 m ³ /h
Minimum suction head @ 50/95°C	0.5/4.5m
Power consumption @ 1 - 230V	3-45W
Nominal Motor Power	37W
Current @ 1 - 230V	0.028 - 0.44 A
Energy Efficiency Index (EEI)	≤ 0.20
Speed	800-4650 rpm
Settings	ΔP-variable (1-7m head) and Constant Speed (I, II and III)
Application	
Maximum Static Pressure	PN6
Temperature range @ maximum ambient temperatures	Maximum ambient temperature 57°C: 0 to 95°C
	Maximum ambient temperature 59°C: 0 to 90°C
	Maximum ambient temperature 67°C: 0 to 70°C
Approved Fluids	Heating Water Water/Glycol - Max 1:1 (above 20% check pumping data)

A1.1.2 PUMP CONTROL PANEL

Wilо Yonos PARA RKC circulating pumps have two possible setting modes:

- Constant speed with three pump speed settings (I, II and III)
- Variable pressure (Δp-v) with pump head adjustable between 1 and 7m head

Figure A1-1 shows the pump control panel with the red selector knob.

Constant Speed Mode (I, II, III)

This is the default setting of the pump and as such is recommended by Grant for heating systems. In this mode the pump speed is not automatically regulated (as with the Variable Pressure Mode), but operates constantly at one of the three possible speeds (set using the red selector knob on the pump control panel).

Variable Pressure Mode (Δp-v)

In this mode the electronic control changes the differential pressure setpoint to be maintained by the pump in a linear fashion between H_s (the value set using the red selector knob on the pump control panel) and ½ H_s. The differential setpoint varies linearly with the volume flow Q.

A1.1.3 INDICATOR LED

The pump is fitted with an indicator LED. This is located around the circumference of the red selector knob. See Figure A1-1 below. This indicates the operating status of the pump and will be illuminated green when the pump is operating normally. This indicator LED can assist in diagnosing and rectifying faults. Refer to Section A1.2.

A1.1.4 SETTING THE PUMP CONTROL MODE

Set the pump to one of the two operating modes as follows:

Constant Speed Mode (I, II, III)

Grant recommends this operating mode for the pump.

To set the pump to the 'Constant Speed' mode, the pointer on the red selector knob must be set to the RIGHT of the mid position. Refer to Figure A1-1.

Set it to point at the required speed setting, I, II or III as required, ensuring that there is adequate flow to distribute the heat from the boiler whilst avoiding high water velocities causing noise in the pipework.

Variable Pressure Mode (Δp-v)

To set the pump to the 'Variable Pressure' mode the pointer on the red selector knob must be set to the LEFT of the mid position. Refer to Figure A1-1.

The further anticlockwise it is set the greater the pressure head setting of the pump – from 1m to 7m head.

If this mode is to be used, set the selector knob at a pressure that represents the maximum pressure (head) loss for the heating system in question.

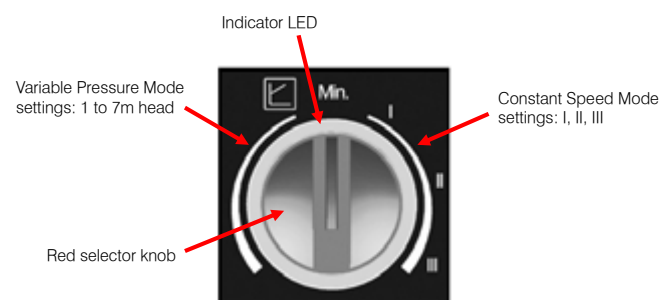

Figure A1-1: Pump control panel with red selector knob and LED indicator

A1.2 CIRCULATING PUMP FAULT DIAGNOSIS - WILO YONOS PARA RS RKC

The indicator LED, located around the circumference of the red control knob can assist in diagnosing and rectifying a fault with the pump. See the table below:

Table A1-2: Pump fault diagnosis

LED condition	Meaning	Diagnostic	Cause	Remedy
Green	Pump operating	Pump runs according to the red knob setting	Normal operation	N/A
Flashes red and green	Pump is operating but stopped	Pump restarts itself after fault has disappeared	Undervoltage Voltage <160V OR Overvoltage Voltage >253V	Check supply voltage is 195V<V<253V
			Overheating: temperature inside motor too high	Check water and ambient temperature
Flashes red	Pump not operating	Pump stopped (blocked)	Pump does not restart itself due to a permanent failure	Replace pump
LED off	No power supply	No voltage to pump control electronics	Pump is not connected to power supply	Check cable connection
			LED is damaged	Check if pump is running
			Electronics are damaged	Replace pump

APPENDIX A2 WILO-PARA 25-130/7-50/SC-6#GRA CIRCULATING PUMP

A2.1 WILO-PARA 25-130/7-50/SC-6#GRA CIRCULATING PUMP

A2.1.1 PUMP SPECIFICATION

Table A2-1: Pump specification

Make and model	Wilo - PARA 25-130/7- 50/SC-6#GRA
Construction	
Pump housing	Cast iron (with cataphoresis treatment)
Impellar	PP composite with GF 40%
Pump shaft	Stainless Steel
Bearing	Carbon, metal impregnated
Motor Data	
Speed	2580 - 4700rpm
Power consumption @ 1 - 230V	8.2 - 50W
Current @ 1 - 230V	0.07 - 0.43A
Minimum starting voltage	170V
Minimum running voltage	160V
Peak inrush current	>3A
Starting torque	>25N.cm
Electrical	
Mains connection	1ph 230V AC +10%/-15% 50/60Hz
Protection Class	IPx4D
Insulation Class	F
Motor Protection	Integrated
Performance	
Max. delivery head	7.7m @ Q = 0 m ³ /h
Max. volume flow	3.5 m ³ /h
Minimum suction head @ 50/95°C	0.5/4.5m
Energy Efficiency Index (EEI)	≤ 0.20
Settings	ΔP-variable (1-7m head) ΔP-constant (1-7m head) Constant Speed (I, II and III)
Application	
Maximum Static Pressure	PN10
Fluid Temperature range @ maximum ambient temperatures (See Section A2.1.2)	Maximum ambient temperature 58°C: 0 to 100°C Maximum ambient temperature 62°C: 0 to 90°C Maximum ambient temperature 66°C: 0 to 80°C Maximum ambient temperature 71°C: 0 to 70°C
Approved Fluids	Heating Water Water/Glycol - Max 1:1 (above 20% check pumping data)

A2.1.2 THERMAL PROTECTION FUNCTION

The pump is equipped with a thermal self-protection mode.

If the fluid temperature exceeds the maximum value at a specific ambient temperature, e.g. 90°C at an ambient of 62°C, the pump will automatically reduce the power consumption, reducing the speed and performance of the pump.

In this condition the Run/Fault signal LED will be blinking RED. When normal temperature conditions return the pump will automatically revert to normal operation.

If the fluid temperature increases further, the thermal protection function may stop the pump temporarily.

In this condition the Run/Fault signal LED on the pump will be constant RED until normal temperature conditions return.

A2.1.3 PUMP COMPONENTS

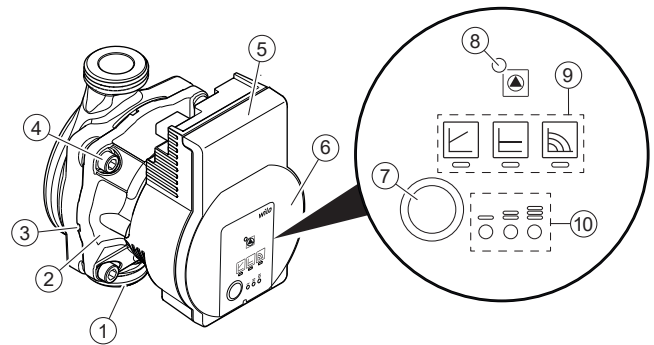

Figure A2-1: Pump components and control panel

1. Pump housing	6. Rating plate
2. Glandless motor	7. Operating button for pump adjustment
3. Condensate drain openings (4 around motor)	8. Run/Fault signal LED
4. Housing screws	9. Display of selected control mode
5. Control module	10. Display of selected pump curve (I, II, III)

A2.1.4 CONTROL PANEL

Indicator LEDs

- Run/Fault signal LED (item 8, Figure A2-1)
 - LED is GREEN when pump is running in normal pump operation.
 - LED lights up red/flashes when there is a fault (refer to Section A2.2).
- Control mode display LEDs (item 9, Figure A2-1)
- Pump curve display LEDs (item 10, Figure A2-1)
- LED combinations are used to indicate when the following functions are in operation:
 - Pump venting (refer to Sections A2.1.5 and A2.1.6 for information on how to activate this function).
 - Manual restart (refer to Sections A2.1.5 and A2.2 for information on how to activate this function).
 - Key lock (refer to Sections A2.1.5 and A2.1.6 for information on how to activate this function).

Operating button - Green (item 7, Figure A2-1)

- Press to select:
 - Control mode
 - Pump curve (within the control mode)
- Press and hold to:
 - Activate the pump venting function (press for 3 seconds)
 - Activate manual restart (press for 5 seconds)
 - Lock/unlock control mode and pump curve (press for 8 seconds)

A2.1.5 OPERATING MODES

Wilo-Para 25-130/7-50/SC-6#GRA circulating pumps have three possible operating modes:

- Variable differential pressure ($\Delta p-v$) with three pre-defined pump curves (I, II and III)
- Constant differential pressure ($\Delta p-c$) with three pre-defined pump curves (I, II and III)
- Constant speed with three pump speed settings (I, II and III)

Variable Differential Pressure Mode ($\Delta p-v$)

Recommended for two-pipe heating systems with radiators to reduce the flow noise at thermostatic valves.

In this mode the electronic control reduces the delivery head of the pump to half in the case of decreasing volume flow in the pipework. There are three pre-defined pump curves (I, II and III) to choose from.

Constant Differential Pressure Mode ($\Delta p-c$)

Recommended for underfloor heating systems.

In this mode the electronic control maintains the set delivery head irrespective of the volume flow from the pump. There are three pre-defined pump curves (I, II and III) to choose from.

Constant Speed Mode

Recommended for systems with fixed system resistance requiring a constant volume flow from the pump.

This is the default setting of the pump and as such is recommended by Grant for heating systems.

In this mode the pump speed is not automatically regulated (as with the Variable or Constant differential pressure modes) but operates constantly at one of the three available speeds (I, II or III)

! NOTE !

Factory default setting is Constant speed mode - pump curve III.

Pump Venting Function

Activated by pressing and holding the green operating button for 3 seconds.

Automatically vents the pump. **This function DOES NOT vent air from the heating system.**

Manual Restart (Unblocking) Function

Activated by pressing and holding the green operating button for 5 seconds.

Unlocks the pump when required, e.g. after a long idle period in the summer.

Key Lock Function

Activated by pressing and holding the green operating button for 8 seconds.

Locks/unlocks the current pump settings set by the operating button, preventing unwanted adjustment of the current pump settings.

Factory Setting Function

Activated by pressing and holding the green operating button whilst switching the pump off, and continuing to hold the button down until all lights on the pump control panel are off.

When the pump is switched back on, it will operate at the original factory settings.

Factory default setting is Constant speed mode - pump curve III.

A2.1.6 COMMISSIONING

After installation of the boiler, commission the pump by using the following procedure:

Venting:

- Fill and vent system correctly. (Refer to Section 7)
- If the pump does not vent automatically use the pump vent function.
- Press and hold the green operating button for 3 seconds and release to start.
- The pump venting function will operate for 10 minutes, during which the pump alternated between off and on to vent air from the pump.
- Pump mode and pump curve LED rows flash in turn at 1 second intervals to indicate when this function is operating.
- To cancel, press and hold green operating button for 3 seconds.
- After 10 minutes the pump automatically reverts to the previously set operating mode, e.g. constant speed -curve III.

! NOTE !

After venting the LED display shows the previous pump settings.

Set Control Mode

- Switch on power to the pump.
- The factory setting is Constant speed mode - pump curve III.
- This will be indicated by the control mode LED and pump curve LED.
- Press the green operating button briefly (approx. 1 second) to change the pump setting.
- Continue to repeat pressing the button, using the following sequence, until the required pump mode and pump curve are set:

Table A2-2: Setting pump control mode

	LED display	Control mode	Pump curve
1		Constant speed	II
2		Constant speed	I
3		Variable differential pressure $\Delta p-v$	III
4		Variable differential pressure $\Delta p-v$	II
5		Variable differential pressure $\Delta p-v$	I
6		Constant differential pressure $\Delta p-c$	III
7		Constant differential pressure $\Delta p-c$	II
8		Constant differential pressure $\Delta p-c$	I
9		Constant speed	III

- Pressing the button for the 9th time returns to the basic setting (constant speed / characteristic curve III).

Lock Operating Button

- To activate the key lock function press and hold the green operating button for 8 seconds until the LEDs for the selected pump settings briefly flash, then release.
- LEDs flash constantly at 1 second intervals to show that key lock is activated.
- The pump settings can no longer be changed unless the key lock function is deactivated.
- To deactivate the key lock function press and hold the green operating button for 8 seconds, as above.

! NOTE !

All settings and displays are retained if the power supply is interrupted.

A2.2 CIRCULATING PUMP FAULT DIAGNOSIS - WILO-PARA 25-130/7-50/SC-6#GRA

The Run/Fault signal LED (item 8, Figure A2-1) will indicate if there is a fault with the pump and can assist in diagnosing and rectifying that fault as detailed in Table A2-3 below:

Table A2-3: Pump fault diagnosis

Run/Fault LED condition	Diagnostic	Cause	Remedy
Green	Normal Operation	Pump runs according to the pump settings	N/A
Red	Pump is stopped	Pump rotor blocked	Activate pump manual restart function
	Winding	Winding defective	
Flashes red	Under/Over voltage	Undervoltage: Voltage < 160V OR Overvoltage: Voltage > 253V	Check mains voltage and operating conditions (water and ambient temperature)
		Excessive motor temperature	
	Short circuit	Motor current too high	
Flashes red/green	Pump stopped (blocked)	Water flowing through pump but no mains voltage to motor	Check mains voltage, water quantity and pressure and ambient conditions.
	Dry running	Air in pump	
	Overload	Sluggish motor with slower speed than normal operation. Pump is operating outside temperature limits.	
LED off	No power to pump control electrics	Pump is not connected to power supply	Check cable connection
		LED is damaged	Check if pump is running
		Electronics are damaged	Replace pump

Manual Restart (Unblocking) Function:

The pump will attempt an automatic restart if a blockage is detected. If this is not successful, the Run/Fault LED will be constant RED.

To activate the manual restart (unblocking) function:

- Press and hold the green operating button for 5 seconds to activate the manual restart function.
- The restart function will run for up to 10 minutes.
- The pump automatically alternates between forward and reverse operation to unblock the pump.
- Pump mode and pump curve LEDs flash in succession in a clockwise direction to indicate when this function is operating.
- To cancel, press and hold the green operating button for 5 seconds.

NOTES



GRANT ENGINEERING (UK) LIMITED

Hopton House, Hopton Industrial Estate, Devizes, Wiltshire, SN10 2EU
Tel: +44 (0)1380 736920 Fax: +44 (0)1380 736991
Email: info@grantuk.com www.grantuk.com